



Energy Division

Street Lighting Catalogue 2007/2008

 **Tyco Electronics**
Our commitment. Your advantage.

Content



Introduction

5



Connection Boxes

11



Enclosures

27



Cable Accessories

37



Tubing, Breakouts and Repair Wraparounds

55



Overhead Line Accessories

61

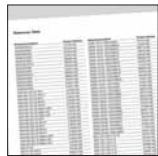

Appendix

67

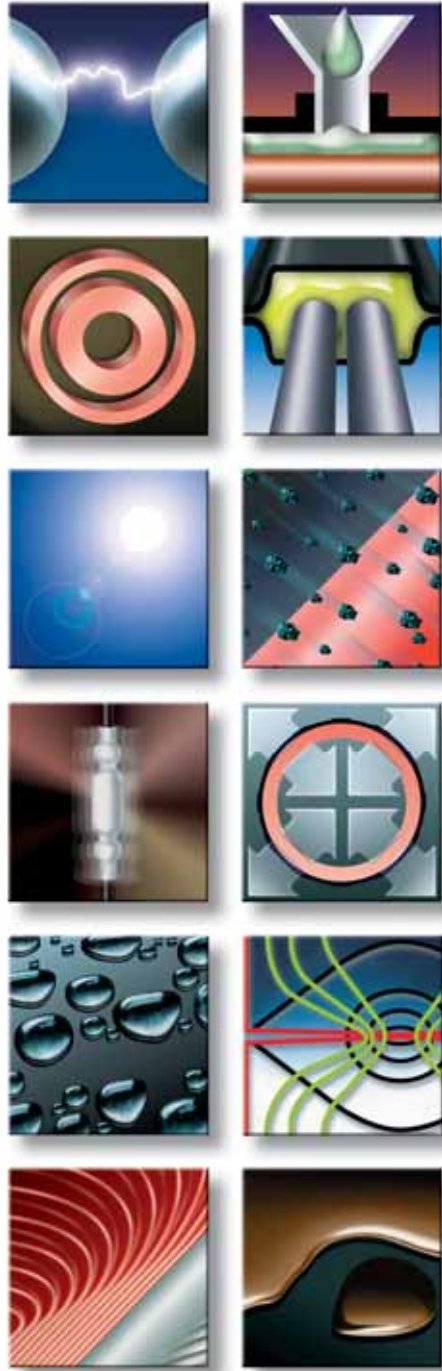

Introduction

General	6
LumaWise – Intelligent Lighting Management System	7
Street Lighting Connection Capability	8

General

Public Lighting is one of the critical tasks of a community administration. Citizens are asking for safe streets, well illuminated traffic and pavements. In many countries the communities are forced by law to assure a certain level of safety. At the same time a street lighting network is one of the most complex electrical installations, widespread and exposed to the public and the demand to save Energy is increasing. To assure a reliable operation of the network, all components need to be capable to withstand the operating conditions, such as:

- all metal parts must be corrosion protected,
- terminals must withstand electrical and thermal cycling,
- all insulating materials must have non-tracking and flame retardant properties,
- parts applied outdoors need to be UV- and environmental resistant.

This catalogue offers components for network solutions to ease installation and maintenance of street lighting networks, underground as well as overhead line operated. These components are especially designed to meet the needs in the street lighting applications and operating conditions to connect and protect the ends of cables from the feeder cabinet to the luminaire, right along the line.

Challenges in the years ahead

If you know what the future holds, you can gear up for what it will bring. Several emerging technology trends will certainly impact outdoor lighting and lighting system monitoring. The writing is on the wall, and provident energy providers are reading it to anticipate tomorrow needs today.

Energy prices are likely to rise in the near future, driving the demand for energy-saving technologies to power municipal lighting companies. The Kyoto Protocol compels signatory states to implement rigorous energy conservation programs. The ambitious goal for the year ahead is to reduce public energy consumption world-wide by five percent. An intelligent outdoor lighting system can help local communities to do their part in mastering this daunting challenge.

In addition, ecology-minded governments are responding to reports of light pollution effects on the nocturnal environment and its consequences for insects and their natural enemies. No city can afford to simply switch off its lights at night, so other measures are called for. Not every street and road requires full illumination all the time. Contingent upon site and situation, a frequently feasible option is to dim lights, thereby striking a balance among conflicting ecological concerns, economical goals, and citizens' safety needs.

If you can capture data on the remaining service life of lamps, ambient temperature, moisture, light intensity, rain, and traffic density, you can permanently lower maintenance costs and roll out new services for your customers. From smart parking lot lighting to event lighting management, the only limit is your entrepreneurial imagination. Let the following pages inform you about abilities of our LumaWise – Intelligent Lighting Management System, which surely convince you with its range of services and cost-curbing potential.

LumaWise Intelligent Lighting Management System

Introduction

An advanced solution for outdoor applications, this new modular lighting and control system manages light points in streets, tunnels and railway stations. Designed to provide the perfect lighting at any time and place, it is an intelligent system that enhances public safety and reduces light pollution.

LumaWise – Ballast and Powerline Modem

The lamp communicates with an AccessPoint via the Powerline Modem. This endows every lamp in network with bidirectional communication capability and enables information to be exchanged with the AccessPoint. This does not mandate in the installation of a decided communication network!

LumaWise – Powerline AccessPoint

The AccessPoint is the system's nerve centre. It monitors and controls terminal equipment in the lamps. If necessary, it works independently, and stores all network control data for three weeks. All the data collected in the AccessPoint are sent to a PC running special monitoring software that affords access and control. Our AccessPoint can monitor far more than 100 end devices, lamps or Powerline CheckPoints.

Driving costs down

As a municipal energy provider, your organization is subject to the laws of efficiency. You are compelled to keep costs in mind and under control, particularly operating overhead incurred throughout an outdoor lighting network's lifecycle.

Now there is an intelligent management system that can significantly decrease these costs. It enables a range of cost-effective products – highly efficient lamps, electronic ballasts and dimming timers – to be deployed to reduce power consumption. And these are just few of many possibilities afforded by our system.

LumaWise also adds tremendous value by turning your lighting system into a communication network. It lets you monitor and remote-control your net via a bidirectional command system. This allows many maintenance processes to be optimized, and some to be eliminated altogether.

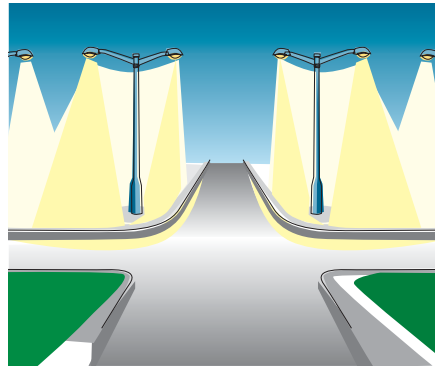

Brighter crossings

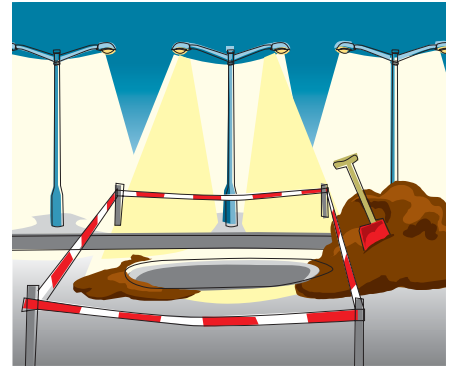

Brighter construction sites

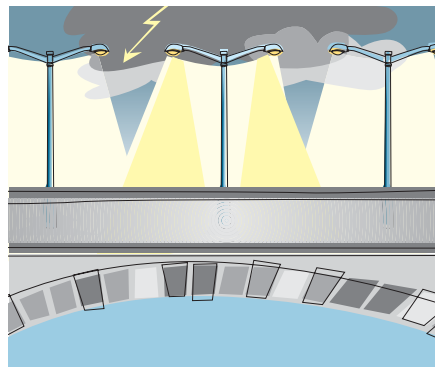

Brighter in foggy and rainy conditions



System indicates defective lamp or remaining lifetime

Your benefits at a glance

- Longer lamp life
- Reduced maintenance costs
- Uniform voltage for energy savings
- Exact power consumption calculation for each device
- Lower lamp replacement costs
- Higher lamp efficiency
- Less ballast energy loss
- Lower power consumption due to dimming
- Enhanced information level and status awareness
- Extended control options

Range of Applications

- Street and Highway Lighting
- Tunnel Lighting
- Airport and Airfield Lighting
- Car Park Lighting
- Lighting of Railway Stations and Tram Lines
- Lighting of Public Areas

Designed to provide the perfect lighting at any time and place to enhance public safety and reduce light pollution.

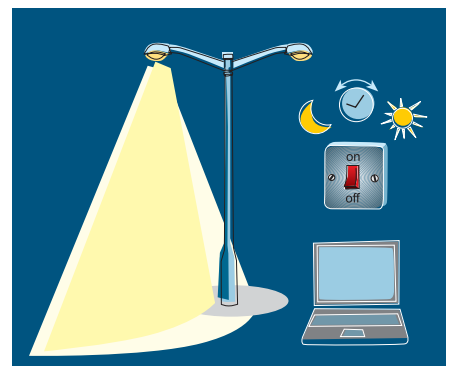

Conclusion

With full communications capability for all on board, modules may be monitored and controlled directly via the power line! What's more, local power line controllers endow the lighting system with automatic control capability and make it traffic and weather responsive.

The modular system is scalable up to a fullfledged city monitoring system that controls lights, watches traffic, and activities indicators and auxiliary equipment. In the event of an unforeseen interruption, the other modules' dynamic repeaters provide backup service to ensure communication flow.

Street Lighting Connection Capability







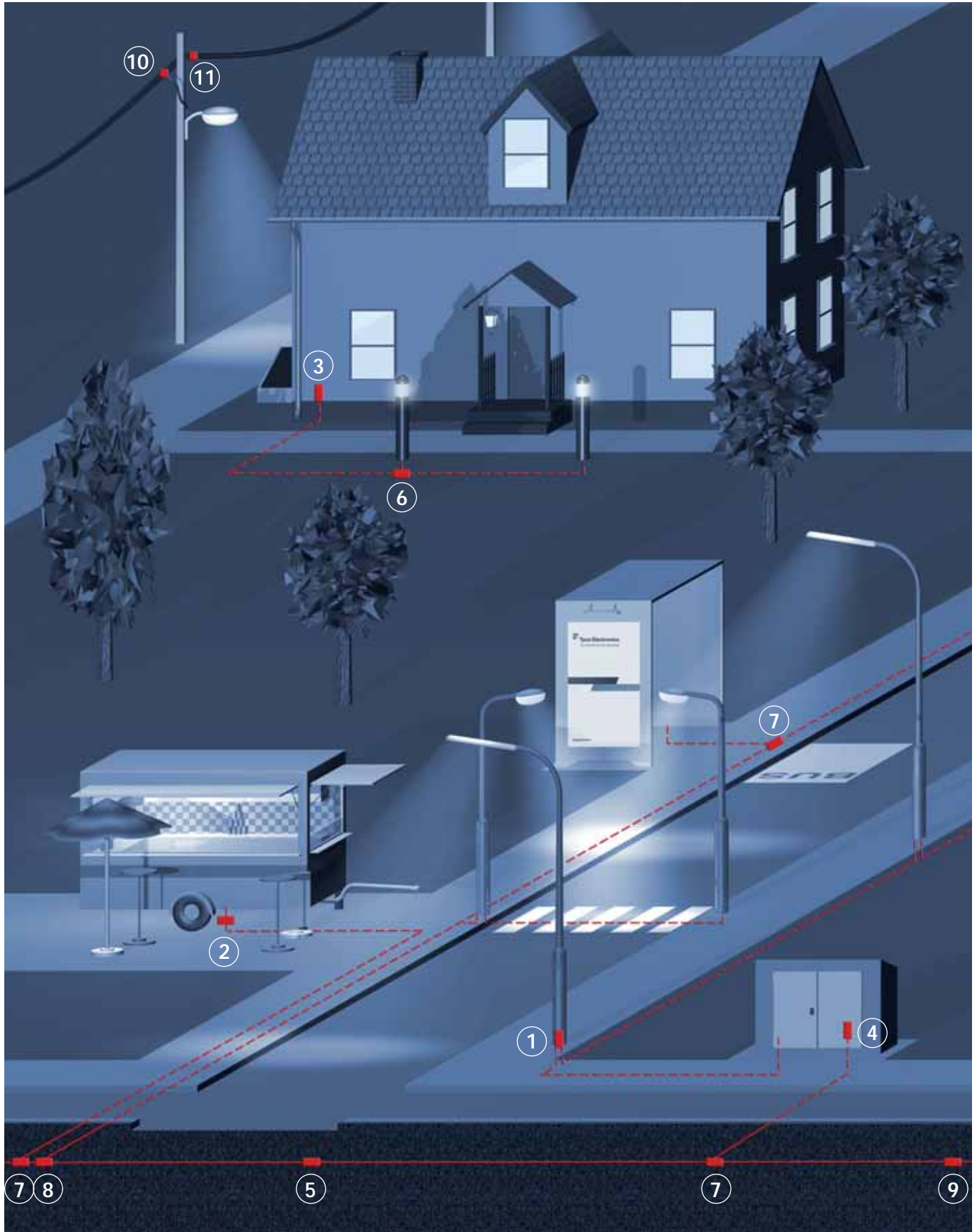



Tyco Electronics Energy Division expertise of over 40 years in materials science, product design and process engineering go into the invention, development,

manufacture and marketing of high performance products. Our wide range of reliable and cost-effective solutions is continuously expanded through research-

driven product development. Under this consideration we have developed different accessories which could be used for street lighting applications.



Street Lighting Connection Capability

	PRODUCT	PAGE
	① EKM (Connection Boxes)	10 – 23
	② UFK (Underground Enclosure)	26 – 34
	③ UPK (In-wall Box)	35
	④ EPKT (Heat-shrinkable Termination)	38
	⑤ POLJ (Heat-shrinkable Joint)	40 – 41
	⑥ RayGel (Gel Joint)	42 – 43
	⑦ BAV, MM-5 (Resin Branch Joints)	45 - 47
	⑧ ASM (Fused Branch Joint)	48
	⑨ CRSM (Wraparound)	59
	⑩ IPC (Tap-off Connectors)	62 – 64
	⑪ Anchor & Suspension Clamps	65

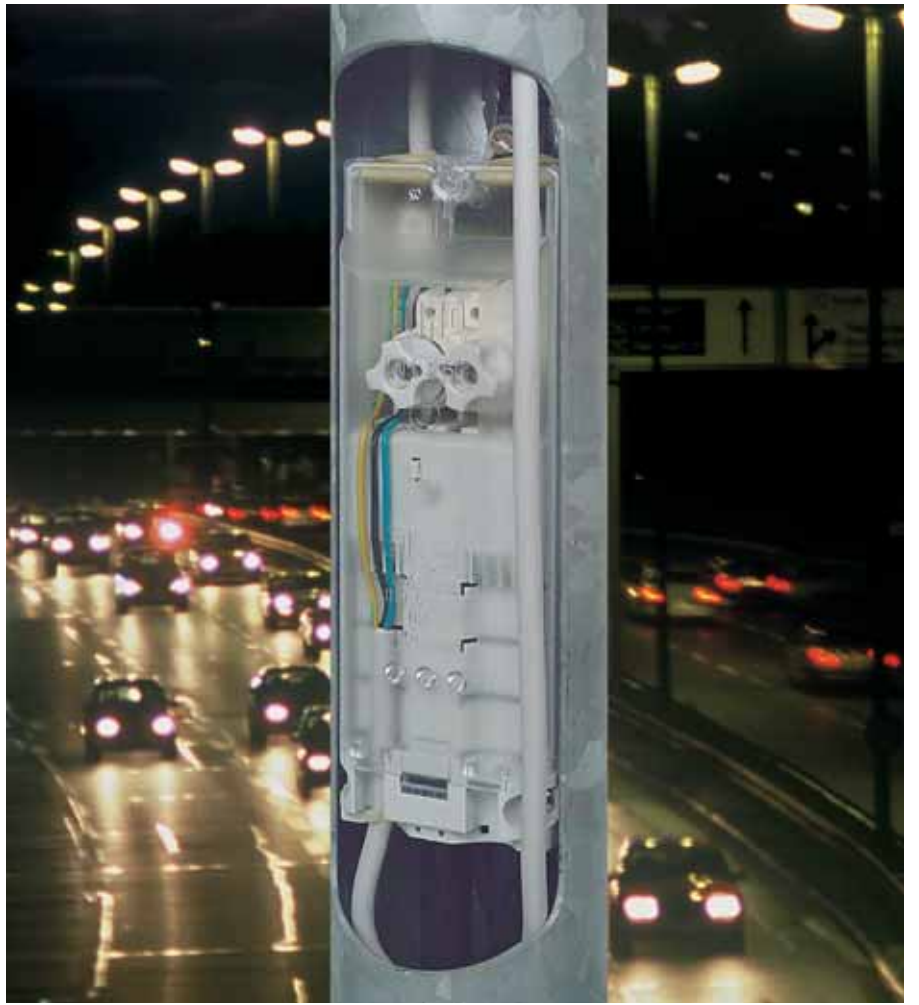

Connection Boxes

Connection Boxes for Lighting Applications

Product overview and selection table	12
For fuses size D 01 (E14):	
EKM 2045 – very small poles and cables	14
EKM 2020 – small poles, small cables	15
EKM 2050 SK – medium poles, medium cables	16
EKM 2050 SKFH – outdoor, medium cables	16
EKM 2051 – special applications with controls	17
For fuses size D II (E27):	
EKM 1271, 1272 – small poles, small, medium cables	18
EKM 1261 – outdoor, small cables	19
EKM 2072 – medium poles, medium cables	20
EKM 1281 – outdoor, medium cables	21
EKM 2035 – large poles, large cables	22
For fuses size 10 x 38:	
EKM 2045-1FN – on walls or outside of poles	23
Accessories and spare parts	
Fuses, adapter screws, screw caps and fused connector B 6770	24
Cable protection frames, adapter hooks and spare connection box covers	25

Connection Boxes for Lighting Applications

Concept

Connection boxes are intended to be used inside lighting poles and outdoor as a connection between underground cables and the lighting equipment and therefore have to have a high degree of reliability. Additional attributes of ingress protection (IP) and insulation protection (class II) provide important operation and maintenance safety features.

Connection boxes can be split into 3 functional areas:

1. Underground cable break-out and connection area
2. Fuse area or DIN-rails
3. Lamp cable connection area

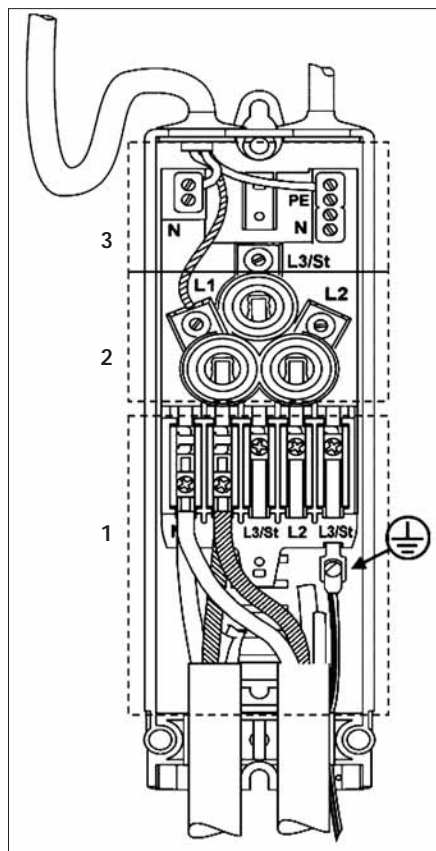

With respect to the size and sturdiness of the underground cable cores, all terminals allow radial assembly. They are designed either as mantle terminals or as sliding terminals.

The fuse area allows placing 1 to 3 fuses for protection of luminaire components and selective protection without influencing other parts of the lighting system. As alternative to fuses, boxes with DIN-rails allow the installation of additional components like timers, MCBs or other electronic devices.

The lamp cable area consists of the terminals, pillar or lug type, and the cable sealing, rubber grommet or compression glands.

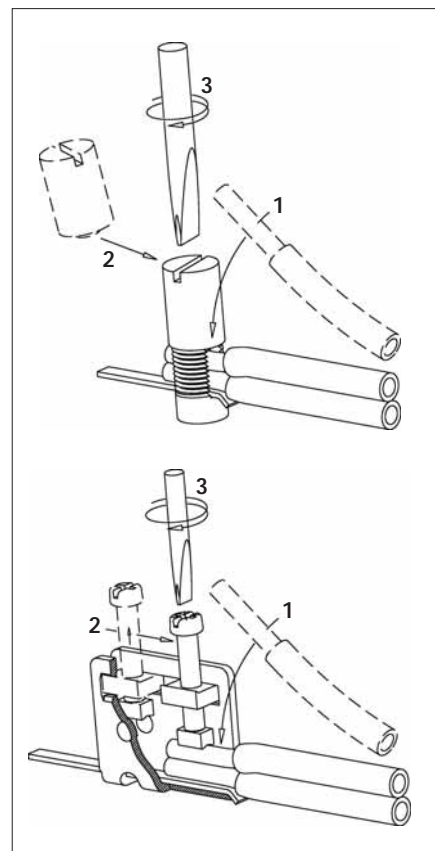

Application sequences with mantle and sliding terminals

Technology

The closures are made from impact resistant, flame retardant thermoplastic materials. All metal parts are either stainless steel or galvanized copper alloys. Fuse sockets are either from ceramics or integrated in high strength glass-fiber reinforced thermoplastics. Depending on the type, the connection boxes have an ingress protection degree of IP 43 to IP 54. Types rated IP 54 are also suitable to be mounted on walls outside.

All connection boxes fulfill protection class II.

The connection boxes fit easily in lighting columns with door openings acc. to EN 40-2 (lighting columns – dimensions and tolerances) and with brackets acc. to DIN 49778 (lighting columns; brackets with sliding nuts for mounting of devices). For poles with horizontal mounting straps, hooks are available as accessories.

Tests

The connection boxes are designed and manufactured in accordance with applicable IEC- and DIN-VDE-standards as:

- IEC-60439 (Low-voltage switchgear and control gear assemblies- Part 1: Type tested assemblies),
- VDE 0660-505 (Switchgear and control gear; Low-voltage switchgear and control gear assemblies; Specification for house fuse boxes and connection boxes),
- DIN 43628 (Fuse boxes for cable protection fuses).

Test certificates are available upon request.

Selection overview

Selection Criteria	Dimensions of Pole (mm)		Application Range of Cables (cross section mm ²)			Fuse Carrier	Terminals	Ingress Protection	Product Name
	Inside Diameter	Door	one	two	three				
very small poles and cables/outdoor	59	58 x 150	5 x 1,5 – 4	5 x 1,5 – 4	–	1 x E14 pre-wired, with fuse	box terminals	IP 55	EKM 2045
small poles and cables	84	70 x 240	5 x 2,5 – 16	5 x 2,5 – 16	5 x 2,5 – 16	2 x E14 pre-wired, with fuse caps	mantle terminals	IP 44	EKM 2020
medium poles and cables/outdoor/ 2 and 3 x E14	90	85 x 270	5 x 2,5 – 25	5 x 2,5 – 25	5 x 2,5 – 16	2/3 x E14 pre-wired, with caps/DIN-rail	sliding terminals	IP 54	EKM 2050
medium poles and cables/outdoor/ special applications	100	85 x 350	5 x 2,5 – 25	5 x 2,5 – 25	5 x 2,5 – 16	2/3/4 x E14/DIN-rails	sliding terminals	IP 54	EKM 2051
medium poles/ small cables/1 x E27	90	80 x 210	4/5 x 6 – 16	4/5 x 6 – 16	–	1 x E27	mantle terminals	IP 43	EKM 1271
medium poles and cables/2 x E27	90	80 x 260	4 x 6 – 25	4 x 6 – 25	–	2 x E27	mantle terminals	IP 43	EKM 1272
outdoor/small cables 1/2 x E27	100	80 x 250	4 x 6 – 16	4 x 6 – 16 5 x 10	– 5 x 10	1/2 x E27/DIN-rail	mantle terminals	IP 54	EKM 1261
medium poles/ large cables	90	80 x 280	5 x 6 – 16 5 x 25 – 35	5 x 6 – 16 5 x 16 – 35	–	1/2 x E27	mantle terminals	IP 43	EKM 2072
outdoor/large cables	120	100 x 300	5 x 25 4 x 35 5 x 25	5 x 16 – 25 4 x 16 – 35 5 x 16	– 5 x 16	1/2 x E27/DIN-rail	mantle terminals	IP 54	EKM 1281
large poles and cables	110	90 x 300	4 x 4 – 50	4 x 4 – 50	4 x 4 – 35	1/2 x E27/DIN-rail	sliding terminals	IP 43	EKM 2035
Wall and outside pole mounting	–	–	3 x 1,5 – 4	–	–	1 x 10 x 38	box terminals	IP 54	EKM 2045-1FN

A wide range of additional connection boxes for other cable dimensions, fuses or accessories is available on request.

EKM 2045 – Connection Box for Lighting Application for D01 (E14) fuses size

Pole Diameter ≥ 59 mm and for Outdoor Application
 Feeder Cables ≤ 4 mm²

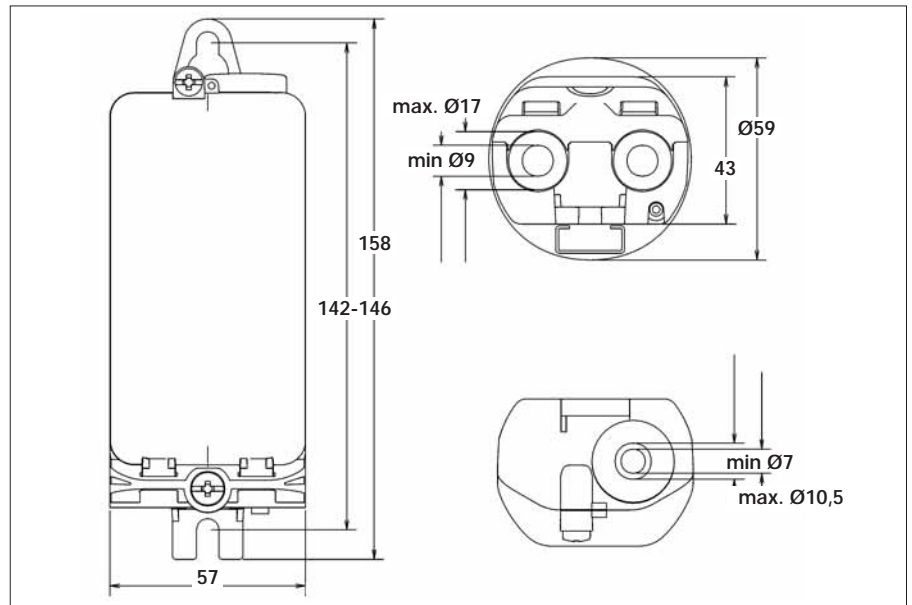

Dimensions in mm

Application

This connection box is intended to be installed in lighting columns at the connection between looped-through feeder cables and the luminaire components protected by fuses.

Selection Criteria

- For application inside of Lighting columns or outdoors
- Pole diameter: ≥ 59 mm
- Door size: $\geq 58 \times 150$ mm
- 5 box terminals
for 2 cables: 1,5 – 4 mm²
- With 1 fuse D01 – 4 A

Technical Data

- Acc. IEC 60439-1 and DIN VDE 0660-505
- Impact resistant thermoplastic
- All metal parts corrosion protected
- Grey cover
- With special fuse holder
- Pre-wired with L1
- Ingress Protection: IP 55
- Class of Protection II
- Range taking self adapting cable sealing
- $\varnothing 9 - 17$ mm feeder cable (2x)
- $\varnothing 7 - 10,5$ mm luminaire cable (for 1 luminaire cables)
- 3 x 1,5 mm² - 3 x 2,5 mm²

Fuse sockets

Cross section (mm²)

for 1 and 2 cables for 3 cables

Ordering description

1 x D 01 – 4A

5 x 1,5 – 4

–

EKM-2045-1D1

Note: Fuse for 4A included. Accessories and spare parts see page 24 and 25.

EKM 2020 – Connection Box for Lighting Application for D01 (E14) fuses size

Pole Diameter ≥ 84 mm
 Feeder Cables ≤ 16 mm²

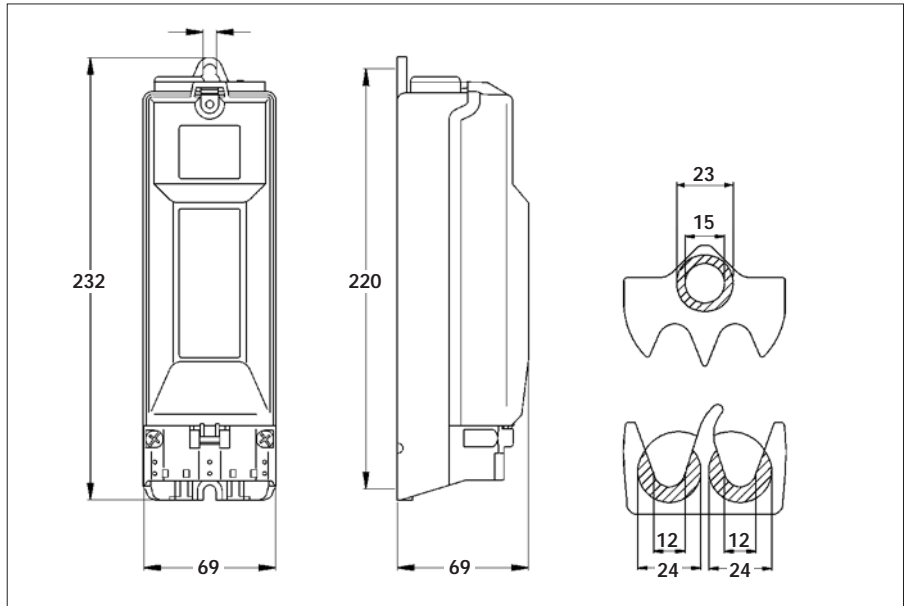

Dimensions in mm

Application

This connection box is intended to be installed for outdoor application or in lighting columns at the connection between looped-through feeder cables and the luminaire components protected by fuses.

Selection Criteria

- For application inside of Lighting columns
 Pole diameter: ≥ 84 mm
 Door size: $\geq 70 \times 240$ mm
- 5 mantle terminals for
 2 cables 2,5 - 16 mm² or
 3 cables 2,5 - 16 mm²
- For 2 fuses D01 (E14) up to 16 A

Technical Data

- Acc. IEC 60439-1 DIN VDE 0660-505 and DIN 43628
- Impact resistant thermoplastic
- All metal parts corrosion protected
- Transparent cover
- With fuse caps
- Pre-wired with bars (N, 1,3,2,PE(N))
- Ingress Protection: IP 44
- Class of Protection II
- Range taking self adapting cable sealing
 $\varnothing 10 - 25$ mm feeder cable (2x)
 $\varnothing 10 - 23$ mm feeder cable (3x)
 $\varnothing 8 - 14$ mm luminaire cable
 2 sealing for 2 luminaire cables
 3 x 1,5 mm² - 5 x 2,5 mm²)
- Luminaire cables alternatively installable downward in parallel to feeder cables max. $\varnothing 11,5$ mm (2x)

Fuse sockets	Cross section (mm ²)		Ordering description
	for 1 and 2 cables	for 3 cables	
2 x D 01 (E14)	5 x 2,5 - 16	5 x 2,5 - 16	EKM-2020-2D1

Note: Fuses not included. Accessories and spare parts see page 24 and 25.

EKM 2050 – Connection Box for Lighting Application for D01 (E14) fuses size

Pole Diameter ≥ 90 mm and for Outdoor Application
 Feeder Cables ≤ 25 mm²

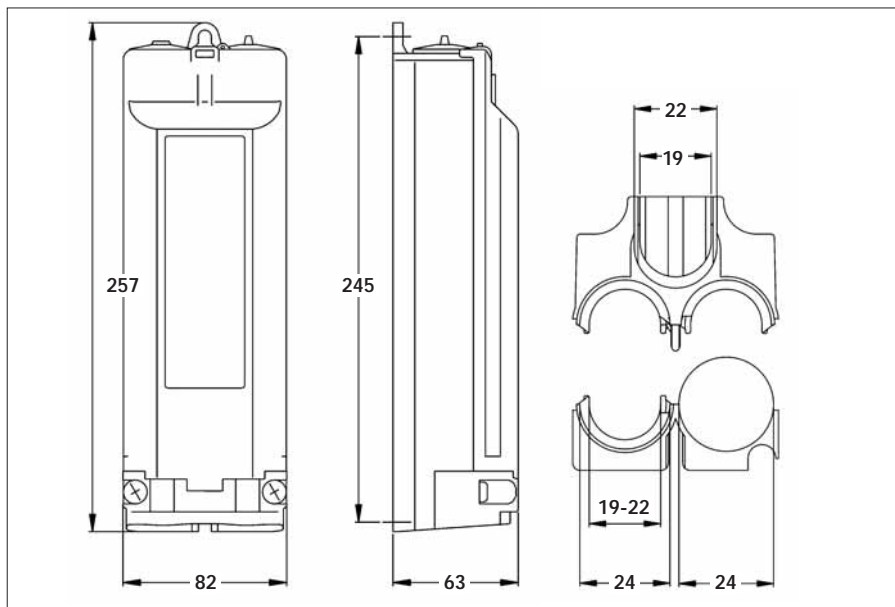

Dimensions in mm

Application

This connection box is intended to be installed inside of lighting columns (SK type) and for outdoor applications (SKFH type) at the connection between looped-through feeder cables and the luminaire components protected by fuses. Additional connection boxes for other cable dimensions, fuses or accessories are available on request.

Selection Criteria

- SK for application inside of lighting columns
 Pole diameter: ≥ 90 mm (D01)
 ≥ 100 mm (DIN-rail)
 Door size: $\geq 85 \times 270$ mm
- SKF and SKFH for outdoor application and inside of lighting columns
- 5 sliding terminals for
 2 cables 2,5 - 25 mm² or
 3 cables 2,5 - 16 mm²
- Types with DIN-rail: For standard installation devices attachable up to 3 TE width (3 x 18 mm), max. height of devices 64 mm. Height of connection box 82 mm.

Technical Data

- Acc. IEC 60439-1 DIN VDE 0660-505 and DIN 43628
- Impact resistant thermoplastic
- All metal parts corrosion protected
- Transparent (SK) or grey (SKF, SKFH) cover

- Fuse sockets with screw caps
- Pre-wired with bars (N, L1, L3, L2, PE(N))
- Ingress Protection: IP 54
- Class of Protection II
- Range taking cable sealing for feeder cables
 $\varnothing 19 - 24$ mm (2x)
 $\varnothing 19 - 22$ mm (3x)
- SK, SKF type with range taking sealing grommets for luminaire cables:
 $\varnothing 8 - 14$ mm luminaire cable
 (2 sealing for 2 luminaire cables
 3 x 1,5 mm² - 5 x 2,5 mm²)
- SKFH type with compression sealing glands for luminaire cables:
 $\varnothing 8 - 14$ mm luminaire cable
 (2 sealing for 2 luminaire cables
 3 x 1,5 mm² - 5 x 2,5 mm²)
- Luminaire cables alternatively installable downward in parallel to feeder cables, max. $\varnothing 11,5$ mm (2x)

Fuse sockets	Cross section (mm ²)		Ordering description
	for 1 and 2 cables	for 3 cables	
SK for application in columns			
2 x D01 (E14)	5 x 2,5 - 25	5 x 2,5 - 16	EKM-2050SK-2D1U
3 x D01 (E14)	5 x 2,5 - 25	5 x 2,5 - 16	EKM-2050SK-3D1U
SKF for outdoor application and in columns			
none, DIN-rail*	5 x 2,5 - 25	5 x 2,5 - 16	EKM-2050SKF-0D0-1R
SKFH for outdoor application and in columns			
2 x D01 (E14)	5 x 2,5 - 25	5 x 2,5 - 16	EKM-2050SKFH-2D1U
3 x D01 (E14)	5 x 2,5 - 25	5 x 2,5 - 16	EKM-2050SKFH-3D1U
none, DIN-rail*	5 x 2,5 - 25	5 x 2,5 - 16	EKM-2050SKFH-0D0-1R

* Connector block only and 1 DIN-rail

Note: Fuses not included. Accessories and spare parts see page 24 and 25.

EKM 2051 – Connection Box for Lighting Application for D01 (E14) fuses size

Pole Diameter ≥ 100 mm for special equipment
 Feeder Cables ≤ 25 mm²

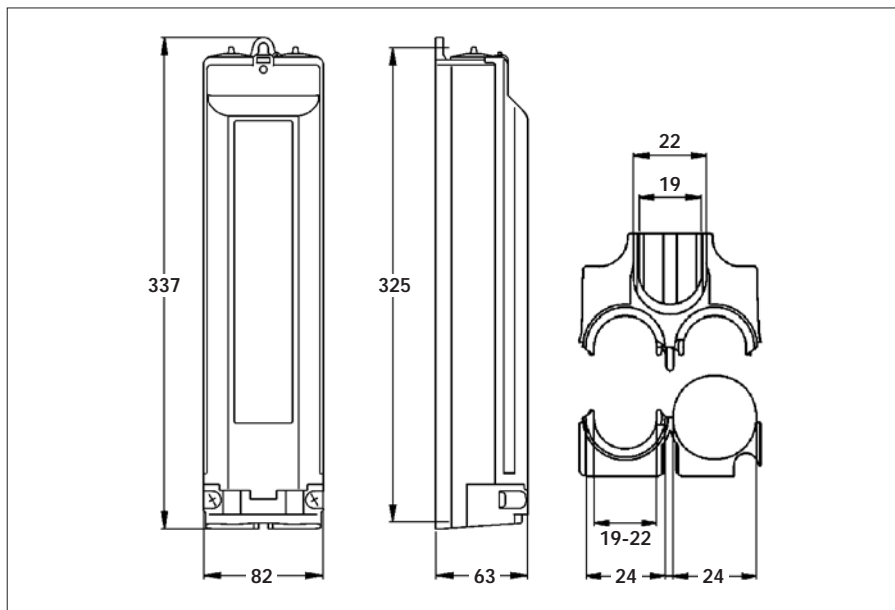

Dimensions in mm

Application

This connection box is intended to be installed in lighting columns at the connection between looped-through feeder cables and the luminaire components. Special equipment as MCBs, timers, residual current devices or the like can be integrated on DIN rails. Additional connection boxes for other cable dimensions, fuses or accessories are available on request.

Note: Connection boxes equipped with connector block, fuse holders or DIN-rails. Timers or MCBs are not part of offered product.

Selection Criteria

- For application inside of lighting columns
 Pole Diameter: ≥ 100 mm
 Door Size: $\geq 85 \times 350$ mm
- 5 sliding terminals for
 2 cables 2,5 – 25 mm² or
 3 cables 2,5 - 16 mm²
- Optional Fuses D01 (E14) up to 16 A
- Optional for standard installation devices on DIN-rail attachable up to 3 TE width (3 x 18 mm), max. height of devices 69,5 mm.

Technical Data

- Acc. IEC 60439-1 DIN VDE 0660-505 and DIN 43628
- Impact resistant thermoplastic
- All metal parts corrosion protected
- Transparent (SK) or grey (SKF, SKFH) cover

- Ingress Protection: IP 54
- Class of Protection II
- Range taking cable sealing for feeder cables
 $\varnothing 19 - 24$ mm (2x)
 $\varnothing 19 - 22$ mm (3x)
- SK, SKF type with range taking sealing grommets for luminaire cables:
 $\varnothing 8 - 14$ mm luminaire cable (2 sealing for 2 luminaire cables 3 x 1,5 mm² – 5 x 2,5 mm²)
- SKFH type with compression sealing glands for luminaire cables:
 $\varnothing 8 - 14$ mm luminaire cable (2 sealing for 2 luminaire cables 3 x 1,5 mm² - 5 x 2,5 mm²)
- Luminaire cables alternatively installable downward in parallel to feeder cables, max. $\varnothing 11,5$ mm (2x)

Fuse sockets	Cross section (mm ²)		Ordering description
	for 1 and 2 cables	for 3 cables	
SK for application in columns			
2 x D01 (E14)	5 x 2,5 – 25	5 x 2,5 – 16	EKM-2051SK-2D1U
2 x D01 (E14), DIN-rail*	5 x 2,5 – 25	5 x 2,5 – 16	EKM-2051SK-2D1S-1R
none, DIN-rails **	5 x 2,5 – 25	5 x 2,5 – 16	EKM-2051SK-0D0-2R
SKF for outdoor application and in columns			
none, DIN-rail*	5 x 2,5 – 25	5 x 2,5 – 16	EKM-2051SKF-0D0-2R
SKFH for outdoor application and in columns			
2 x D01 (E14)	5 x 2,5 – 25	5 x 2,5 – 16	EKM-2051SKFH-2D1U
3 x D01 (E14)	5 x 2,5 – 25	5 x 2,5 – 16	EKM-2051SKFH-3D1U-1R
4 x D01 (E14)	5 x 2,5 – 25	5 x 2,5 – 16	EKM-2051SKFH-4D1U

* Connector block, with fuse holders and 1 adjustable DIN-rail

** Connector block only and 2 adjustable DIN-rails

Note: Fuses not included. Accessories and spare parts see page 24 and 25.

EKM 1271, EKM 1272 – Connection Box for Lighting Application for DII (E27) fuses size

Pole Diameter ≥ 90 mm
Feeder Cables ≤ 25 mm²

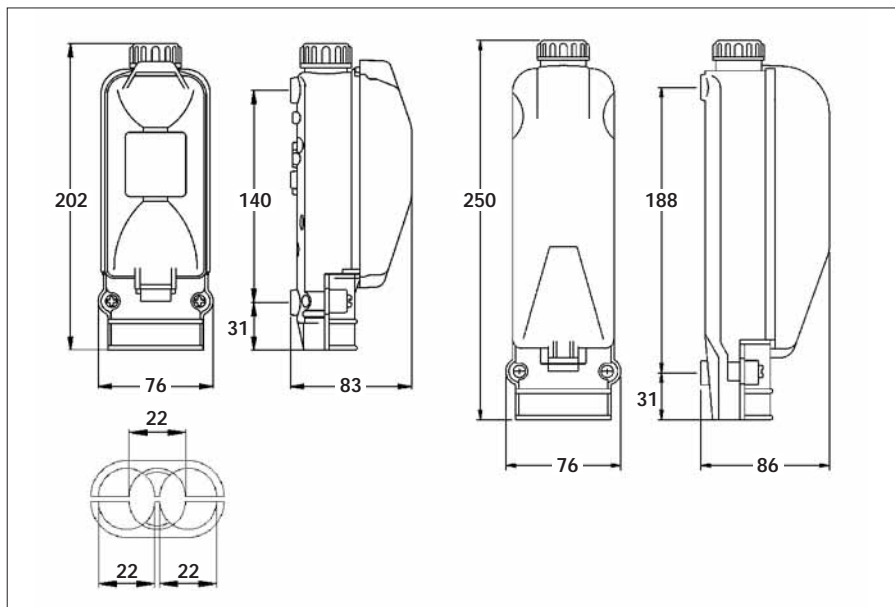

Dimensions in mm

Application

This connection box is intended to be installed in lighting columns at the connection between looped-through feeder cables and the luminaire components protected by fuses.

Selection Criteria

- For application inside of lighting columns
Pole diameter: ≥ 90 mm
Door size:
EKM 1271 $\geq 80 \times 210$ mm
EKM 1272 $\geq 80 \times 260$ mm
- 4 or 5 mantle terminals for 2 cables
EKM 1271/1272 6 – 16 mm² or
EKM 1272 10 – 25 mm²
- Fuses D II (E27) up to 25 A

Technical Data

- Acc. IEC 60439-1
- Impact resistant thermoplastic
- All metal parts corrosion protected
- Transparent fuse cover
- Degree of Protection: IP 43
- Class of Protection II
- Entry for feeder cables
max. $\varnothing 22$ mm (2x)
- Compression sealing glands for luminaire cables: $\varnothing 8 - 14$ mm luminaire cable
(for 1 luminaire cable
3 x 1,5 mm² – 5 x 2,5 mm²)

Fuse sockets

Cross section (mm²)

	Cross section (mm ²)		Ordering description
	for 1 and 2 cables	for 3 cables	
1 x DII (E27)	4 x 6 – 16	–	EKM-1271-1D2-4-16
1 x DII (E27)	5 x 6 – 16	–	EKM-1271-1D2-5-16
2 x DII (E27)	4 x 6 – 16	–	EKM-1272-2D2-4-16
2 x DII (E27)	4 x 10 – 25	–	EKM-1272-2D2-4-25

* Connector block only and 1 DIN-rail

Note: Fuses, adapter screws and screw caps not included. Accessories and spare parts see page 24 and 25.

EKM 1261 – Connection Box for Lighting Application for DII (E27) fuses size

Pole Diameter ≥ 100 mm and Outdoor Application
 Feeder Cables ≤ 16 mm²

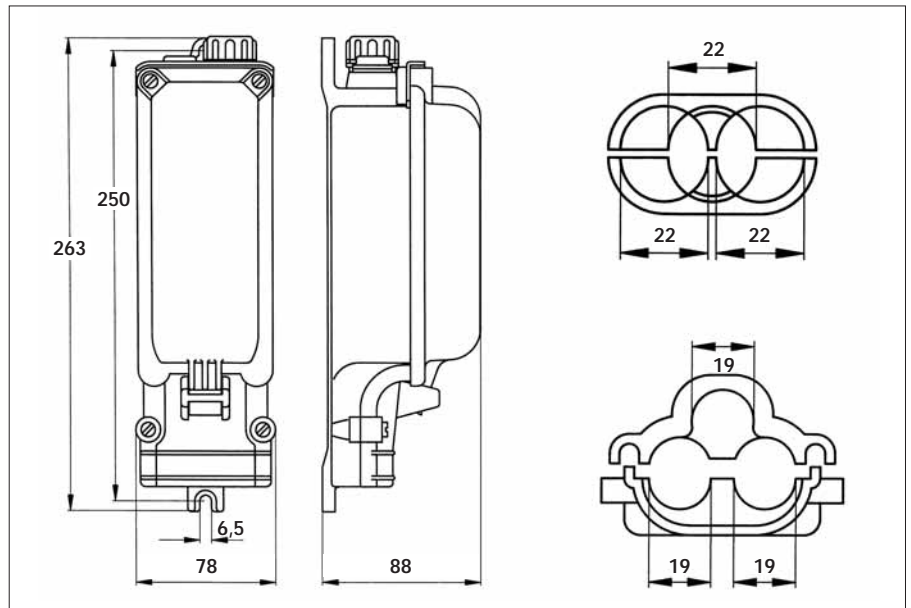

Dimensions in mm

Application

This connection box is intended to be installed for outdoor application and inside of lighting columns at the connection between looped-through feeder cables and the luminaire components protected by fuses.

Selection Criteria

- For application inside of lighting
- For application inside of lighting columns or outdoors:
 Pole diameter: ≥ 100 mm
 Door size: $\geq 80 \times 250$ mm
- 4 or 5 mantle terminals for 2 cables $6 - 16$ mm²
- Fuses D II (E27) up to 25 A

Technical Data

- Acc. IEC 60439-1
- Impact resistant thermoplastic
- All metal parts corrosion protected
- Transparent fuse cover
- Ingress Protection: IP 54
- Class of Protection II
- Entry for feeder cables
 max. $\varnothing 22$ mm (2x, 3x)
 without insert max. $\varnothing 25$ mm (2x)
- Compression sealing glands for luminaire cables: $\varnothing 8 - 14$ mm luminaire cable (2 glands in case of type 2D2 for 2 luminaire cables
 $3 \times 1,5$ mm² – $5 \times 2,5$ mm²)

Fuse sockets	Cross section (mm ²)		Ordering description
	for 1 and 2 cables	for 3 cables	
1 x DII (E27)	4 x 6 – 16	–	EKM-1261-1D2-4-16
1 x DII (E27)	5 x 6 – 16	–	EKM-1261-1D2-5-16
2 x DII (E27)	4 x 6 – 16	–	EKM-1261-2D2-4-16
2 x DII (E27)	5 x 6 – 16	–	EKM-1261-2D2-5-16
2 x DII (E27)	5 x 10**	5 x 10	EKM-1261-2D2-5-10
none, DIN-rail*	5 x 6 – 16	–	EKM-1261-0D0-5-16-1R

* Connector block only and DIN-rail for up to 3 MCB

** not suitable for 1 cable only

Note: Fuses, adapter screws and screw caps not included. Accessories and spare parts see page 24 and 25.

Boxes without fuse sockets are available on request.

EKM 2072 – Connection Box for Lighting Application for DII (E27) fuses size

Pole Diameter ≥ 90 mm
Feeder Cables ≤ 35 mm²

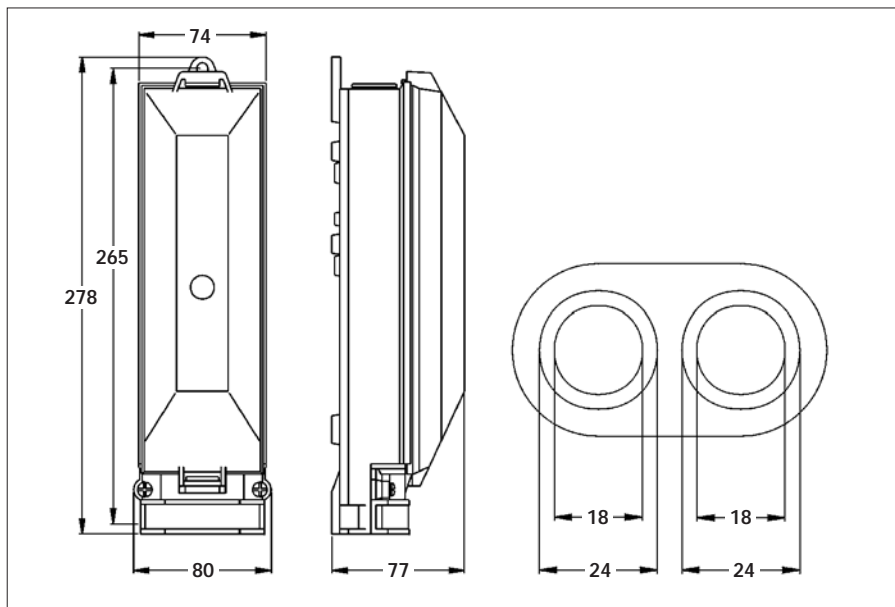

Dimensions in mm

Application

This connection box is intended to be installed in lighting columns at the connection between looped-through feeder cables and the luminaire components protected by fuses.

Selection Criteria

- For application inside of lighting columns
Pole diameter: ≥ 90 mm
Door size: $\geq 80 \times 280$ mm
- 4 or 5 mantle terminals for 2 cables
2 cables 4 – 16 mm² or
2 cables 16 – 35 mm²
- Fuses D II (E27) up to 25 A

Technical Data

- Acc. IEC 60439-1
- Impact resistant thermoplastic
- All metal parts corrosion protected
- Transparent fuse cover
- Degree of Protection: IP 43
- Class of Protection II
- Range taking self adapting cable sealing
Ø 19 – 29 mm feeder cable
Ø 8 – 14 mm luminaire cable
(2 sealing for 2 luminaire cables
3 x 1,5 mm² – 5 x 2,5 mm²)

Fuse sockets

Cross section (mm²)

Ordering description

	Cross section (mm ²)			Ordering description
	for 1 cable	for 2 cables	for 3 cables	
1 x D II (E27)	5 x 6 – 16	5 x 6 – 16	–	EKM-2072-1D2-5-16
2 x D II (E27)	5 x 6 – 16	5 x 6 – 16	–	EKM-2072-2D2-5-16
1 x D II (E27)	4 x 25 – 35	4 x 16 – 35	–	EKM-2072-1D2-4-35
2 x D II (E27)	4 x 25 – 35	4 x 16 – 35	–	EKM-2072-2D2-4-35
1 x D II (E27)	5 x 25 – 35	5 x 16 – 35	–	EKM-2072-1D2-5-35
2 x D II (E27)	5 x 25 – 35	5 x 16 – 35	–	EKM-2072-2D2-5-35

Note: Fuses, adapter screws and screw caps not included. Accessories and spare parts see page 24 and 25.

EKM 1281 – Connection Box for Lighting Application for DII (E27) fuses size

Pole Diameter ≥ 120 mm and Outdoor Application
 Feeder Cables ≤ 35 mm²

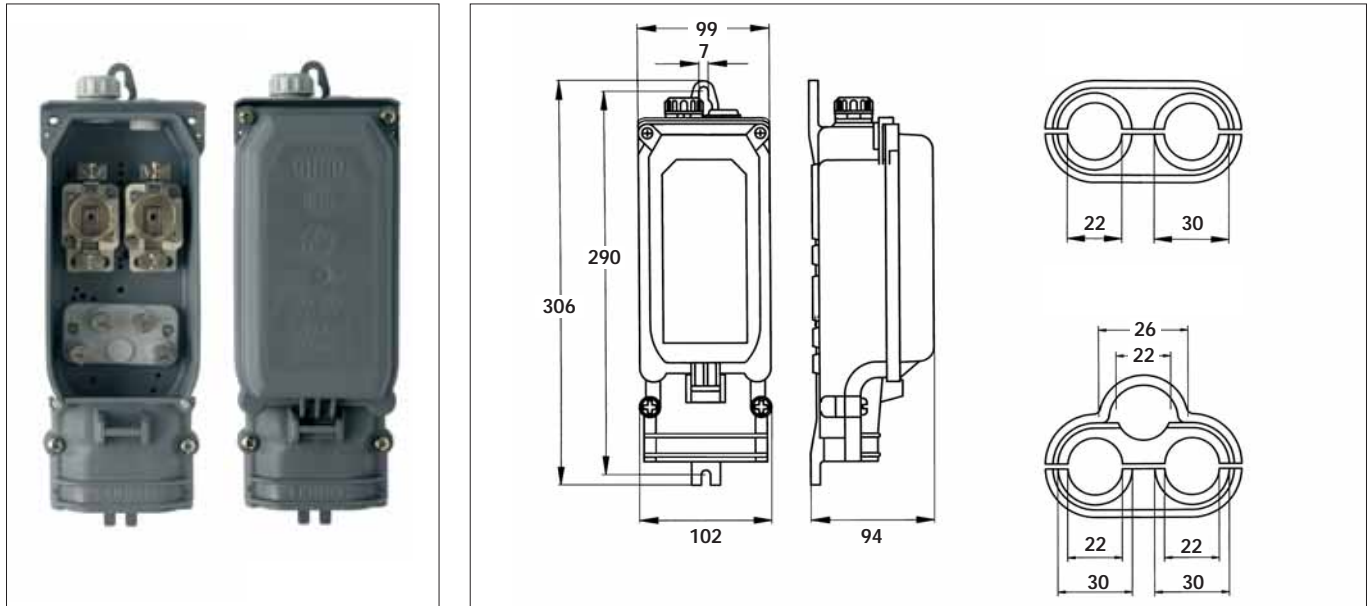

Dimensions in mm

Application

This connection box is intended to be installed for outdoor application and inside of lighting columns at the connection between looped-through feeder cables and the luminaire components protected by fuses.

Additional connection boxes for other cable dimensions, fuses or accessories are available on request.

Selection Criteria

- For application inside of lighting columns and outdoors:
 Pole diameter: ≥ 120 mm
 Door size: $\geq 100 \times 300$ mm
- 4 or 5 mantle terminals for
 2 cables 16 - 25 mm² or
 2 cables 16 - 35 mm²
- Fuses D II (E27) up to 25 A

Technical Data

- Acc. IEC 60439-1
- Impact resistant thermoplastic
- All metal parts corrosion protected
- Ingress Protection: IP 54
- Class of Protection II
- Entry for feeder cables
 $\varnothing 22 - 30$ mm (2x)
- Compression sealing glands for luminaire cables:
 $\varnothing 8 - 14$ mm luminaire cable
 (2 glands for 2 luminaire cables
 $3 \times 1,5$ mm² – $5 \times 2,5$ mm²)

Fuse sockets	Cross section (mm ²)			Ordering description
	for 1 cable	for 2 cables	for 3 cables	
1 x DII (E27)	5 x 25	5 x 16 – 25	–	EKM-1281-1D2-5-25
2 x DII (E27)	4 x 25	4 x 16 – 25	–	EKM-1281-2D2-4-25
2 x DII (E27)	4 x 35	4 x 16 – 35	–	EKM-1281-2D2-4-35
2 x DII (E27)	5 x 25	5 x 16	5 x 16	EKM-1281-2D2-5-16
2 x DII (E27)	5 x 25	5 x 16 – 25	–	EKM-1281-2D2-5-25
none, DIN-rail*	4 x 35	4 x 16 – 25	–	EKM-1281-0D0-4-35-1R

* Connector block only and DIN-rail for up to 3 MCB

Note: Fuses, adapter screws and screw caps not included. Accessories and spare parts see page 24 and 25.

Boxes without fuse sockets are available on request.

EKM 2035 – Connection Box for Lighting Application for DII (E27) fuses size

Pole Diameter ≥ 110 mm
 Feeder Cables ≤ 50 mm²

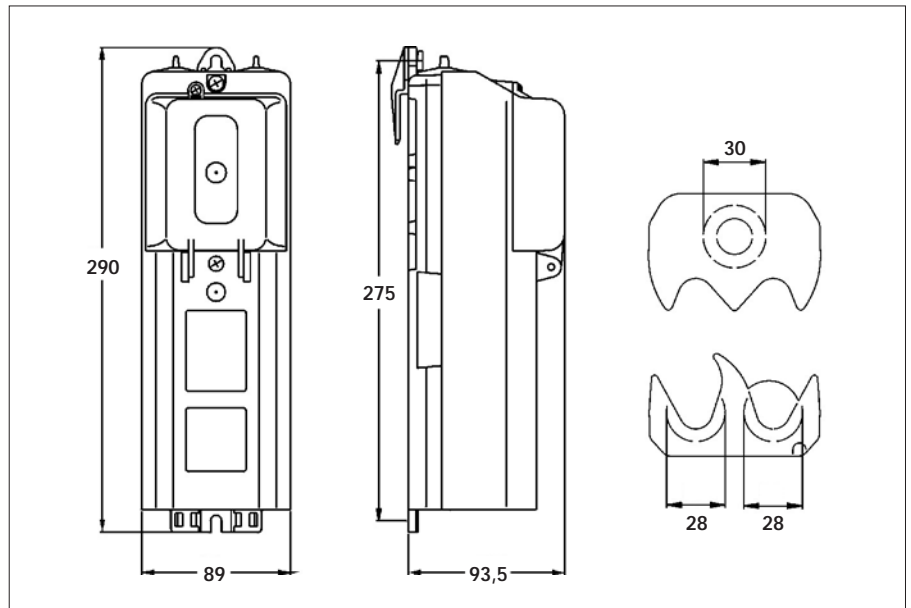

Dimensions in mm

Application

This connection box is intended to be installed in lighting columns at the connection between looped-through feeder cables and the luminaire components protected by fuses. Special equipment as MCBs, timers, residual current devices or the like can be integrated on DIN rails.

Selection Criteria

- For application inside of Lighting columns
 Pole diameter: ≥ 110 mm
 Door size: $\geq 90 \times 300$ mm
- 4 sliding terminals for
 2 cables 4 – 50 mm² or
 3 cables 4 – 35 mm²
- Optional Fuses D II (E27) up to 25 A
- Optional for standard installation devices on DIN-rail attachable up to 3 TE width (3 x 18 mm), max. height of devices 75 mm.

Technical Data

- Acc. IEC 60439-1
- Impact resistant thermoplastic
- All metal parts corrosion protected
- Transparent fuse cover
- Ingress Protection: IP 43
- Class of Protection II
- Range taking self adapting cable sealing
 $\varnothing 16 - 35$ mm feeder cable
 $\varnothing 8 - 14$ mm luminaire cable
 (2 sealing for 2 luminaire cables
 $3 \times 1,5$ mm² – $5 \times 2,5$ mm²)
 or 2 x 4 wires $\varnothing 1,5 - 3$ mm

Fuse sockets

Cross section (mm²)

Ordering description

	Cross section (mm ²)		Ordering description
	for 1 and 2 cables	for 3 cables	
1 x D II (E27)	4 x 4 - 50	4 x 4 - 35	EKM-2035-1D2
2 x D II (E27)	4 x 4 - 50	4 x 4 - 35	EKM-2035-2D2
none*	4 x 4 - 50	4 x 4 - 35	EKM-2035-0D0
none, DIN-rail**	4 x 4 - 50	4 x 4 - 35	EKM-2035-0D0-1R

* Connector block only and screws for fuse sockets

** Connector block only and DIN-rail for up to 3 MCB

Note: Fuses, adapter screws and screw caps not included. Accessories and spare parts see page 24 and 25.

EKM 2045-1FN – Connection Box for Lighting Application for 10 x 38 fuses size

Outdoor Application
 Feeder Cables $\leq 4 \text{ mm}^2$

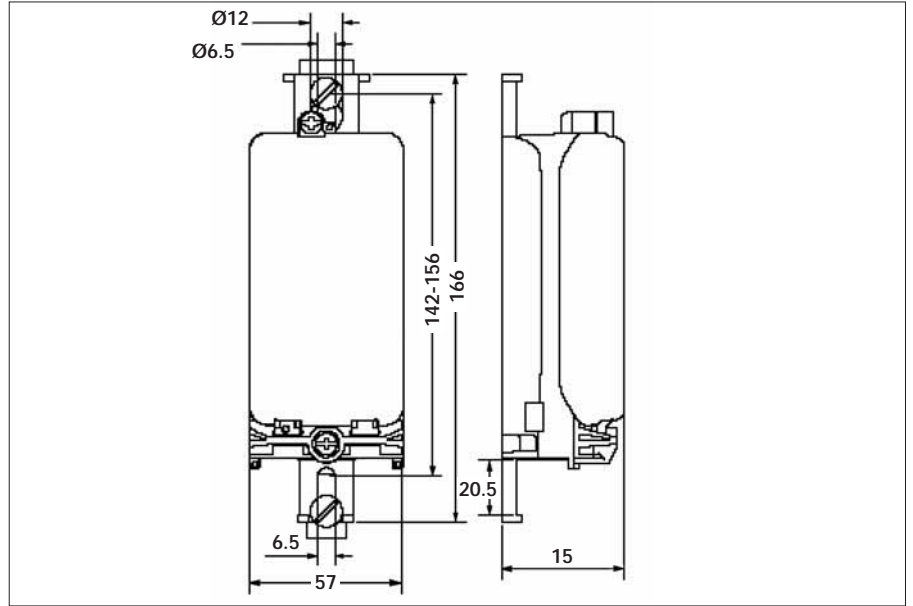

Dimensions in mm

Application

This connection box is intended to be installed on walls or outside of poles. The box is connected between the feeder cable (up to 4 mm^2) and the luminaire. Feeder cables are either branch cables from underground joints or connected to overhead lines. Fixing to wall with 6 mm screws or fixing to poles with up to 20 mm wide steel straps.

Selection Criteria

For outdoor application on walls or outside of (concrete) poles with overhead line supply.

Technical Data

- Acc. IEC 60439-1
- Impact resistant thermoplastic
- Available in 4 colours
- With special fuse holder including neutral disconnect
- Ingress Protection: IP 54
- Class of Protection II
- Range taking self adapting cable sealing $\varnothing 9 - 17 \text{ mm}$ feeder/luminaire cable

Fuse sockets	Cross section (mm^2)	Pinning	Colour	Ordering description
1 x for 10 x 38	3 x 1,5 – 4	L, N	grey	EKM-2045-1FN-G-EE
1 x for 10 x 38	3 x 1,5 – 4	L, N, PE	grey	EKM-2045-1FNT-G-EE
1 x for 10 x 38	3 x 1,5 – 4	L, N	ivory	EKM-2045-1FN-I-EE
1 x for 10 x 38	3 x 1,5 – 4	L, N, PE	ivory	EKM-2045-1FNT-I-EE
1 x for 10 x 38	3 x 1,5 – 4	L, N	brown	EKM-2045-1FN-M-EE
1 x for 10 x 38	3 x 1,5 – 4	L, N, PE	brown	EKM-2045-1FNT-M-EE
1 x for 10 x 38	3 x 1,5 – 4	L, N	black	EKM-2045-1FN-N-EE
1 x for 10 x 38	3 x 1,5 – 4	L, N, PE	black	EKM-2045-1FNT-N-EE

Note: Fuses not included. Accessories and spare parts see page 24 and 25.

Fuses, screw caps, adapter screws and fused connectors



Fused connector **B 6770**, complete with fuse type D01 (E14)

For mounting in narrow poles or to fuse directly at the luminaire component.
For connection cables on both sides up to 4 mm².

Nominal current	Ordering description
2 A	GURO-B6770-2A
4 A	GURO-B6770-4A
6 A	GURO-B6770-6A
10 A	GURO-B6770-10A



Fuse accessories type D01 (E14)

Nominal current	Ordering description Fuses D01 (E14)	Adapter screws	Screw cap
-			GURO-F-D1-SC
2 A	GURO-F-D1-02	GURO-F-D1-AS02	
4 A	GURO-F-D1-04	GURO-F-D1-AS04	
6 A	GURO-F-D1-06	GURO-F-D1-AS06	
10 A	GURO-F-D1-10	GURO-F-D1-AS10	
16 A	GURO-F-D1-16	-	

Fuse holders for size D01 can also be used without adapter screws



Fuse accessories type DII-E27

Nominal current	Ordering description Fuses DII (E27)	Adapter screws	Screw cap
-			GURO-F-D2-SC
2 A	GURO-F-D2-02	GURO-F-D2-AS06	
4 A	GURO-F-D2-06	GURO-F-D2-AS06	
10 A	GURO-F-D2-10	GURO-F-D2-AS10	
16 A	GURO-F-D2-16	GURO-F-D2-AS16	
20 A	GURO-F-D2-20	GURO-F-D2-AS20	
25 A	GURO-F-D2-25	GURO-F-D2-AS25	

Fuse holders for size DII can only be used with the appropriate adapter screw

Fuse of 10 x 38 size

Nominal current	Ordering description
2 A	GURO-F-CC-02
4 A	GURO-F-CC-04
6 A	GURO-F-CC-06
10 A	GURO-F-CC-10
16 A	GURO-F-CC-16

Cable protecting frames for lighting poles, spare covers for connection boxes, adapter hooks



Cable protection frames for poles according to EN40

The frames are inserted in the standardized (EN 40) underground cable openings and protect the cable insulation against damage from sharp edges. Stays in position even when cables will be pulled back. For cable entry opening 50 x 150 mm acc. to EN 40. Material: Polyethylen
Snap-in-design, fit all diameters > 90 mm

Ordering description	Cable entry opening (mm)	min. pole diameter (mm)
GURO-B6924	50 x 150	90



Adapter hook for transversal rail in poles

The adapter hook has a self-fastening feature when inserted into the hanging eye of the connection box. The adapter hook, fixed to the connection box, is slid behind the transversal rail and thus providing a hook for hanging the connection box on. Dimensions: Width 30 mm, depth 19 mm, high 58 mm, hook diameter 10,5 mm. Material: PP

Ordering description	Dimensions (mm)	Hook diameter (mm)
GURO-B7324	30 x 58 x 19	10,5/6,2

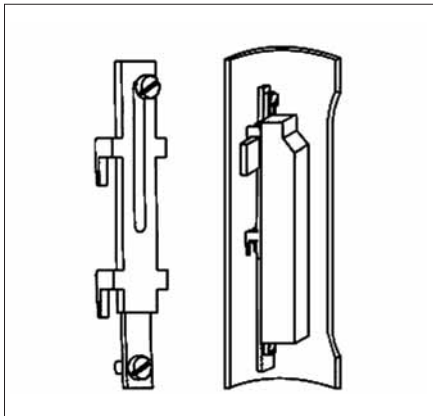

Adapter hooks **GURO-Hxxxx** consist of an aluminium rail and a sliding double hook. They are fixed to the fuse boxes back and can be adjusted to the appropriate position. Note that minimum pole diameter increases by 10 mm compared to the dimensions stated for the fuse boxes alone. The length of the aluminium rail is adapted to the fuse boxes length.

Ordering description	Hook for connection box type
GURO-H2050	EKM-2050
GURO-H2051	EKM-2051
GURO-H2035	EKM-2035
GURO-H2072	EKM-2072
GURO-H2020	EKM-2020
GURO-H1261	EKM-1261
GURO-H1281	EKM-1281



Spare covers for connection boxes

Ordering description	Cover for connection box type
GURO-B7224	EKM-2020
GURO-B7182-01	EKM-2050SK
GURO-B7182-03	EKM-2050SKFH
GURO-B7217-11	EKM-2051
GURO-B6692	EKM-1271
GURO-B6602	EKM-1272
GURO-B6622	EKM-1261
GURO-B7142	EKM-2072
GURO-B6705	EKM-1281



Enclosures

Underground Enclosures

Product overview and selection table	28
UFK D40 – with plug outlet	30
UFK D125 – with connection box	31
UFK D200-16-R-FI-1 – with 1-phase 16 A plug outlet	32
UFK D200-16 – with 3-phase 16 A plug outlet	33
UFK D200-12V – with 12 V/100 W power supply	34

In-Wall Enclosures

UPK 3000/3002	35
---------------	----

Underground Enclosures – Pavement embedded, floodable boxes

Concept

Street furniture and decorative lighting equipment not always give space for adequate installation protection equipment; in other cases, temporary need of power supply cannot be arranged with acceptable effort.

This product line provides space and protection for the necessary equipment underground with access for authorized persons only.

The underground enclosures are designed to provide minimum depth to allow application directly above the cable lines.

Technology

The electrical equipment – fuse boxes incorporating the necessary equipment and, if applicable, plug outlets, is placed under a standard street cap, providing protection against load up to 12,5 t. Protection against flooding is provided by means of one or more diving bells, keeping the water away from functional parts just by maintaining the air pressure inside, while the water is climbing outside. For maintenance and access, the diving bells can be easily removed and the fuse box can be retracted from underground and positioned above ground level for easy access and maintenance. The connection between the fuse box and the connected underground cables is provided by means of flexible, helically wound cables.

The housing is made from standardized pipe components approved for underground application.

The connection between the underground cables and the flexible cable is protected by durable polyurethane resin, well known from low voltage cable joints.

Applicable Standards

- Street caps are approved acc. EN 124
- For resin potted connections, CENELEC HD 628 applies
- Other electrical components are in compliance with IEC 60439-1

Test certificates are available upon request.

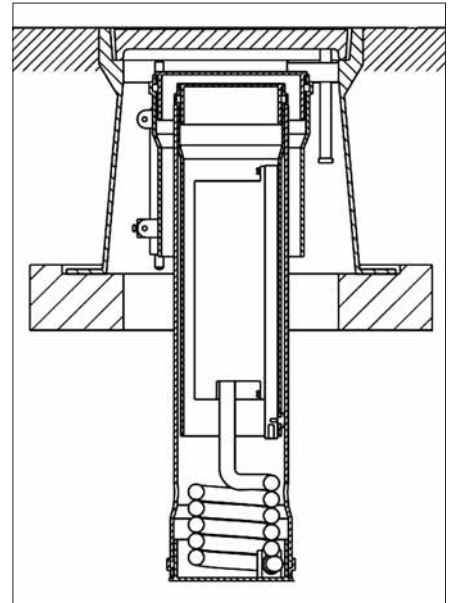
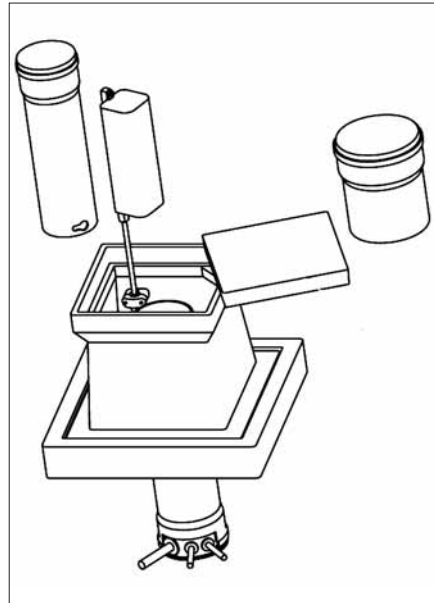

Selection overview

Features	Rated current	Cable cross section	Length of supplied cable	Dimension of Street cap (mm)	Product Name
Plug outlet for temporary decorative illumination	1 x 10 A	3 x 6 mm ²	3 m	190 x 190	UFK D40
Protection of permanently installed street furniture	3 x 16 A	Line: 4 x 10 mm ² Load: 5 x 2,5 mm ²	Line: 3 m Load: 3 m	290 x 290	UFK D125
Protected 1-phase 16 A plug outlet, ground fault protection included	1 x 16 A	Line: 4 x 10 mm ²	3 m	290 x 290	UFK D200-16-R-FI-1
Protected 3-phase 16 A plug outlet for temporary connection of distribution boards	3 x 16 A	Line: 4 x 10 mm ²	3 m	290 x 290	UFK D200-16*
Protected 12 V, 100 W power supply for class III equipment (pond and pool illumination)	Line side: 4 A Load side: 9 A	Line: 5 x 6 mm ² Load: 3 x 1,5 mm ²	Line: 3 m Load: 5 m	290 x 290	UFK D200-12V

* Operation intended by authorized and qualified personnel only



The application of UFK D125 as a connection point for electrical control of solenoid in a gas lamp pole.

UFK D40 – Underground Enclosures with plug outlet

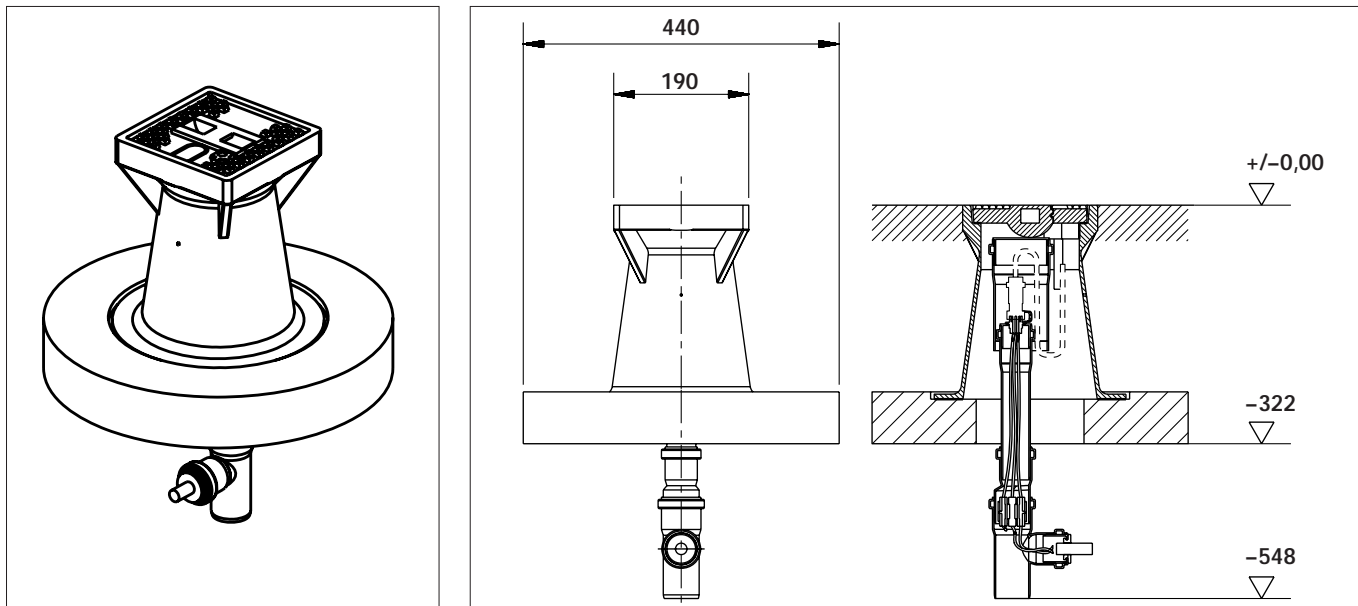

Dimensions in mm

Application

This underground enclosure contains a plug outlet for temporary connection of decorative lighting.

Technical Data

Single phase, N, L, PE
 Line cable: NYY-J 3 x 6 mm², 3 m long
 Plug-outlet: AMP- CPC circular connector
 Rated current: 10 A
 Rated voltage: 240 V
 Max. load for street cap: 12,5 kN
 Visible area: 190 x 190 mm
 Max Depth: 548 mm
 Approx. Weight: 32 kg
 Flood protection of diving bell works with original gas-tight connection cable only.

Article

Underground enclosure
 Connection cable 3 x 1,5 mm², 5 m,
 w. CPC circular connector gas-tight

Ordering description

UFK D40
 GURO-CC3x1,5-5-CPC-GT

Schematic

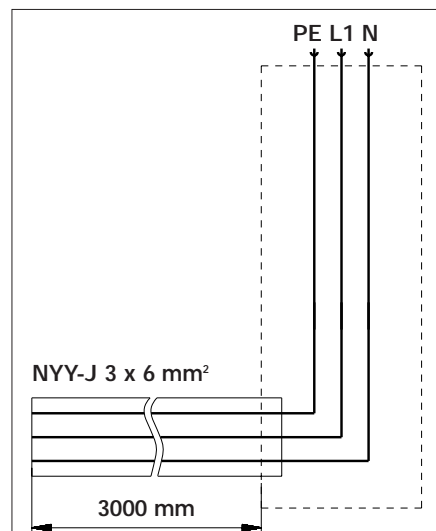

UFK D125 – Underground Enclosures for protection of Street Equipment

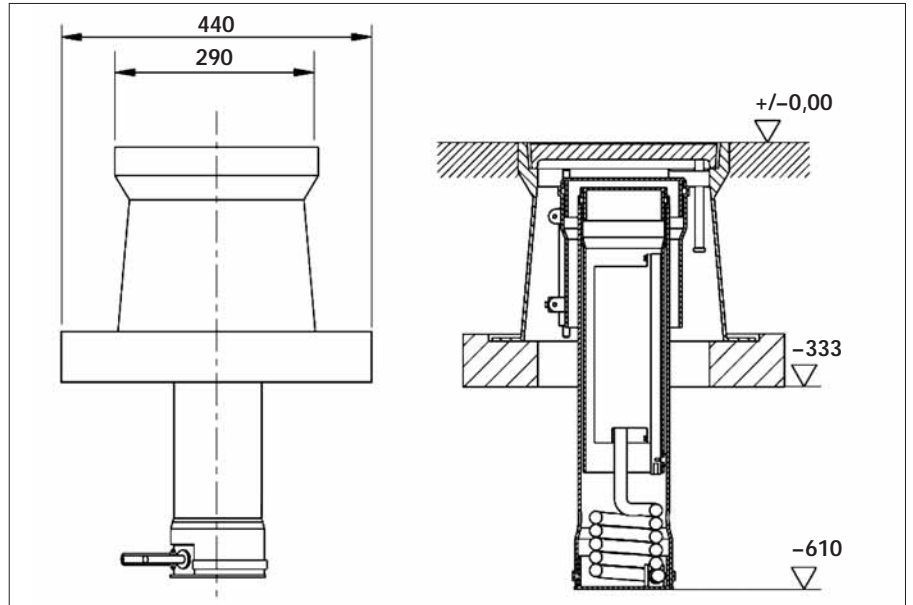
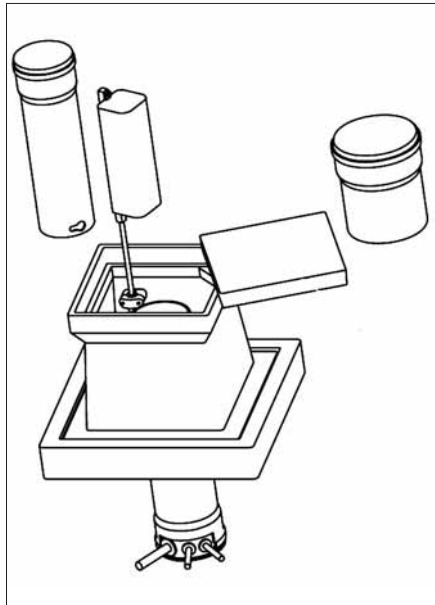

Dimensions in mm

Application

This underground enclosure contains a fuse box, providing protection for permanently connected 3-phase applications. It serves as connection point between the utility network (TN-C) and the customer network (TN-S). Fuse box is removable from the enclosure and can be positioned above ground level for maintenance.

Selection Criteria

Underground enclosures are available with or without closure means for protection against unauthorized access. They are available with fuse box.

Technical Data

Line side: L1, L2, L3, PEN
 Load side: L1, L2, L3, N, PE
 Line cable: NYY-J 4 x 10 mm², 3 m long
 Load cable: NYY-J 5 x 2,5 mm², 3 m long
 Rated current: 16 A
 Rated voltage: 400 V
 Max. load for street cap: 12,5 kN
 Visible area: 290 x 290 mm
 Max Depth: 610 mm
 Approx. Weight: 68 kg

Article

Underground enclosure
 without lockable street cap

Ordering description

UFK D125

Underground enclosure
 with lockable street cap

UFK D125-R

Schematic

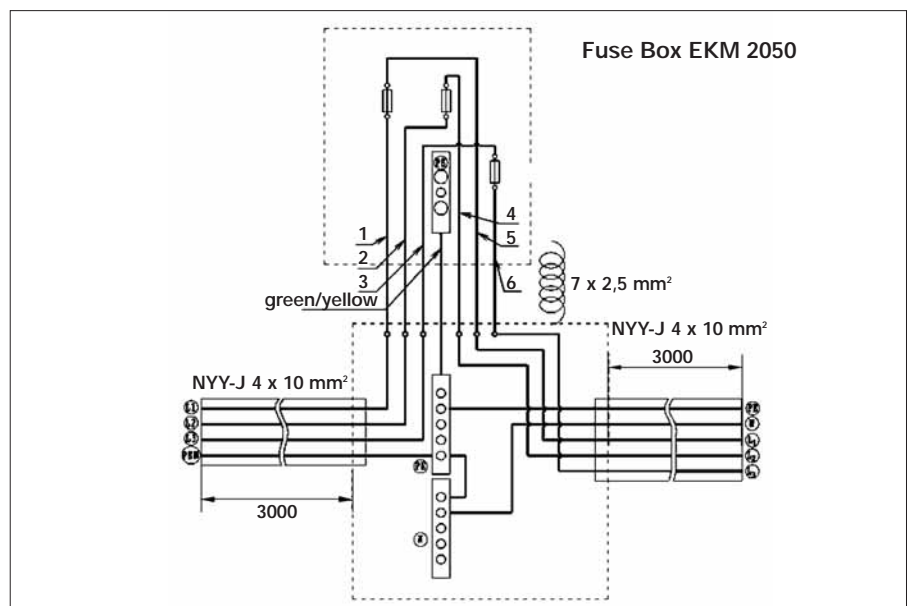

UFK D200-16-R-FI-1 – Underground Enclosures with single phase 16 A plug outlet and ground fault protection

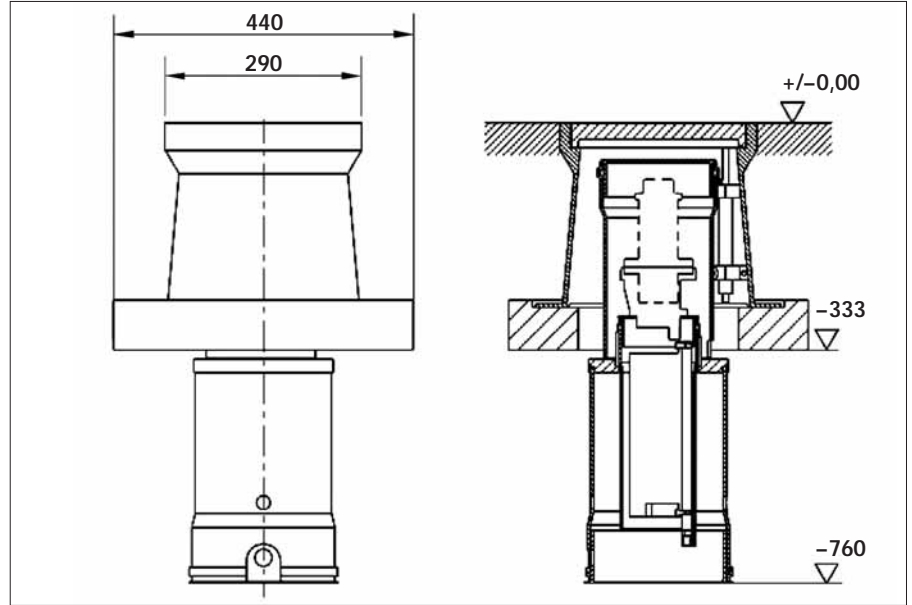
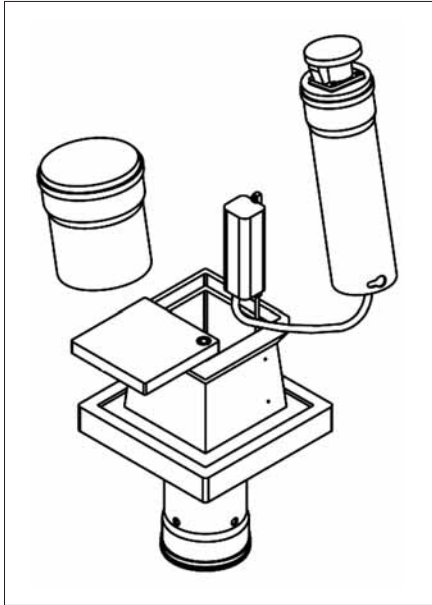

Dimensions in mm

Application

This underground enclosure contains a single phase CEE 16 A plug outlet for temporary connection for markets, fairs etc. Even with plug applied, the outlet remains underground and flood protected under the diving bell, when using the gas tight cable plug available as accessory. An opening in the street cap's cover allows routing the cable out of the closed enclosure.

Fuse box and plug are removable from the enclosure and can be positioned above ground level for maintenance. The equipment is protected against ground fault; therefore the operation is also allowed for unskilled personnel. The street cap cover is locked with a M24 screw.

Technical Data

Line side: L1, L2, L3, PEN
 Load side: CEE-plug outlet L, N, PE
 Line cable: NYY-J 4x10 mm², 3 m long
 Rated current: 16 A
 Rated voltage: 230 V
 Ground fault trip current: 30 mA
 Max. load for street cap: 12,5 kN
 Visible area: 290 x 290 mm
 Max Depth: 760 mm
 Approx. Weight: 73 kg

Article

Underground enclosure
 without lockable street cap

Plug with 5 m long cable,
 Gastight assembled

Ordering description

UFK D200-16-R-FI-1

GURO-CC3x2,5-5-CEE-GT

Schematic

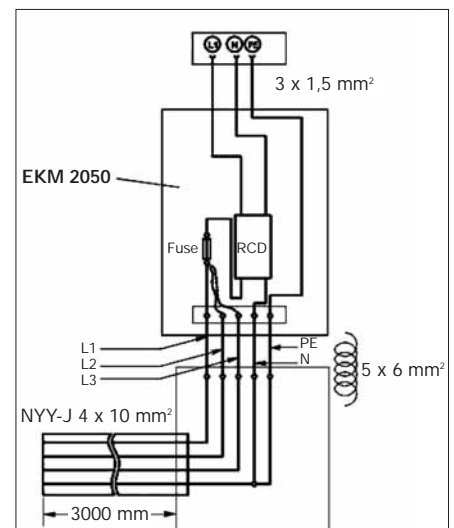

UFK D200-16 – Underground Enclosures with three phase 16 A plug outlet

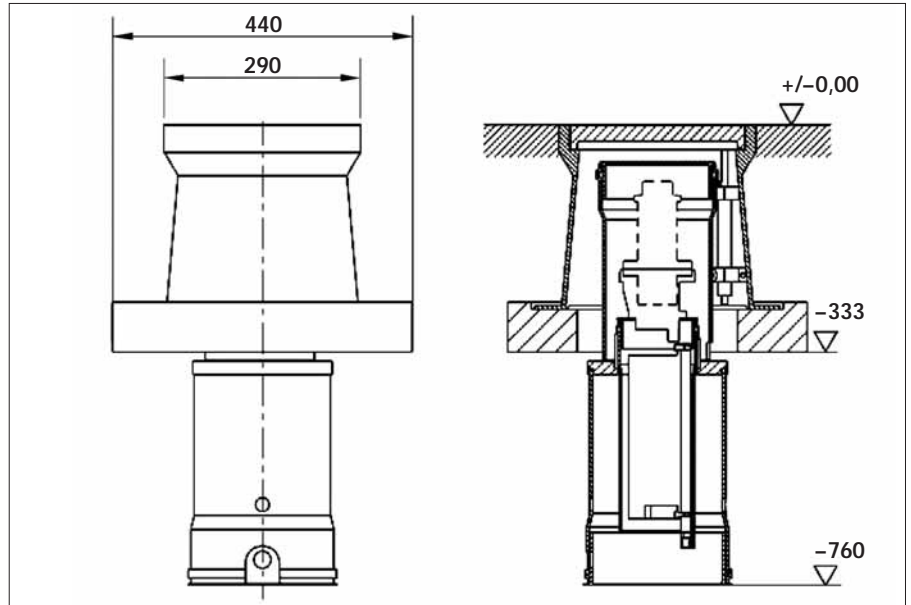
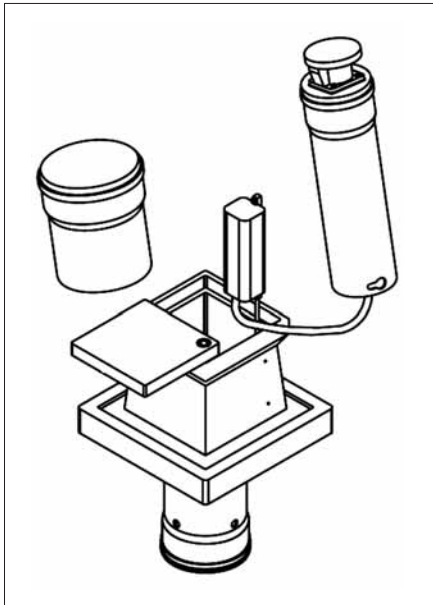

Dimensions in mm

Application

This underground enclosure contains a 3-phase CEE 16 A plug outlet for temporary connection of cabinets for markets, fairs etc. Even with plug applied, the outlet remains underground and flood protected under the diving bell, when using the gas tight cable plug available as accessory. An opening in the street cap's cover allows routing the cable out of the closed enclosure. Fuse box is removable from the enclosure and can be positioned above ground level for maintenance.

The equipment is not protected against ground fault; therefore the equipment is intended for operation by qualified personnel only. Ground fault protection needs to be supplied in the connected distribution cabinet.

Selection Criteria

The street cap cover of underground enclosures is locked with a M24 screw for protection against unauthorized access. A version without lock is available as an option.

Technical Data

Line side: L1, L2, L3, PEN
 Load side:
 CEE-plug outlet L1, L2, L3, N, PE
 Line cable: NYY-J 4x10 mm², 3 m long
 Rated current: 16 A
 Rated voltage: 400 V
 Max. load for street cap: 12,5 kN
 Visible area: 290 x 290 mm
 Max Depth: 760 mm
 Approx. Weight: 73 kg

Article

Underground enclosure
 without lockable street cap

Underground enclosure
 with lockable street cap

Plug with 5 m long cable,
 Gastight assembled

Ordering description

UFK D200-16

UFK D200-16-R

GURO-CC5x2,5-5-CEE-GT

Schematic

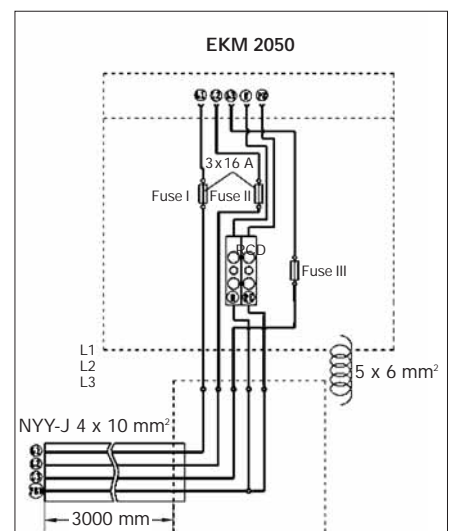

UFK D200-12V – Underground Enclosures with 12 V/100 W power supply

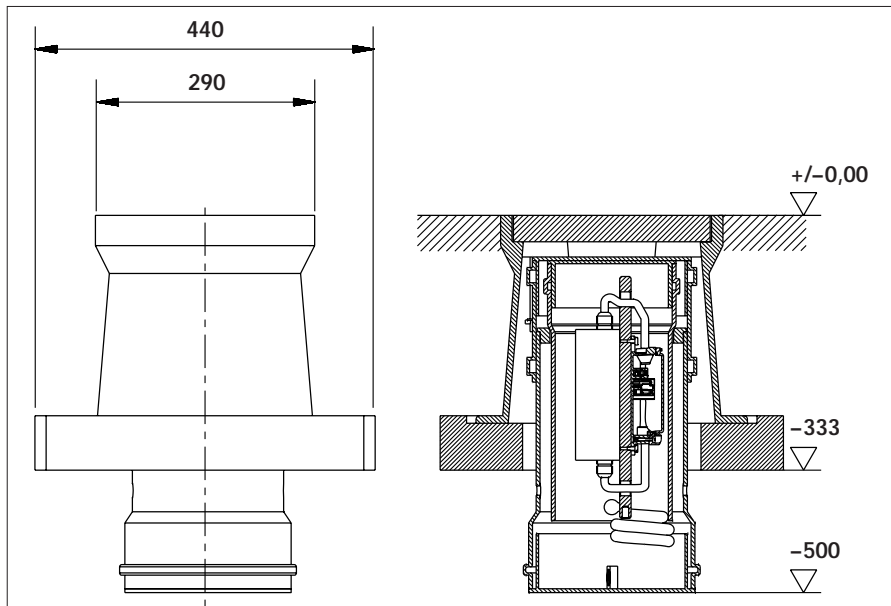
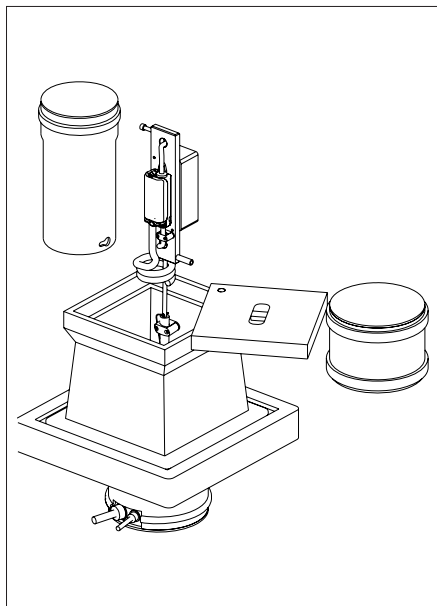

Dimensions in mm

Application

This underground enclosure contains a 12 V 100 W power supply including a single pole fuse protection to supply protection class III equipment, like light spots in pools or ponds.

Technical Data

Line side: L1, L2, L3, N, PE
 Load side: +/-12 V
 Line cable: NYY-J 5 x 6 mm², 3 m long
 Load cable: NYY-J 3 x 1,5 mm², 5 m long
 Rated voltage (Line): 400 V
 Rated current (Line): 4 A

Rated voltage (Load): 12 V
 Rated current (Load): 9 A
 Max. load for street cap: 12,5 kN
 Visible area: 290 x 290 mm
 Max Depth: 500 mm
 Approx. Weight: 73 kg

Article

Underground enclosure with
 12 V 100 W Power Supply

Ordering description

UFK D200-12V

Schematic

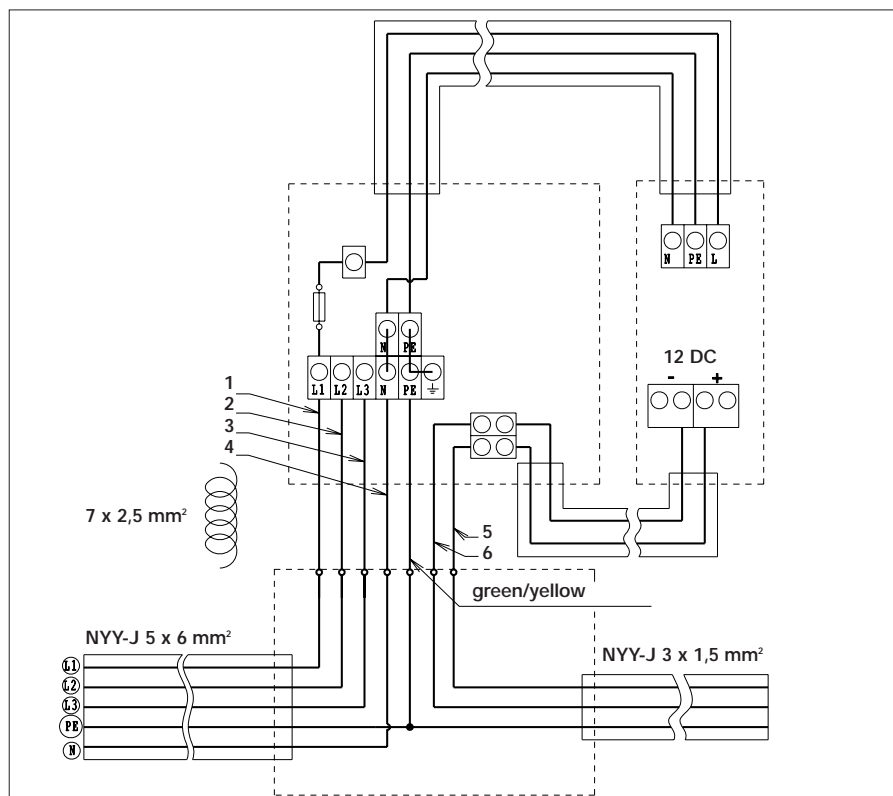

UPK 3000 / 3002 – In-Wall Enclosures

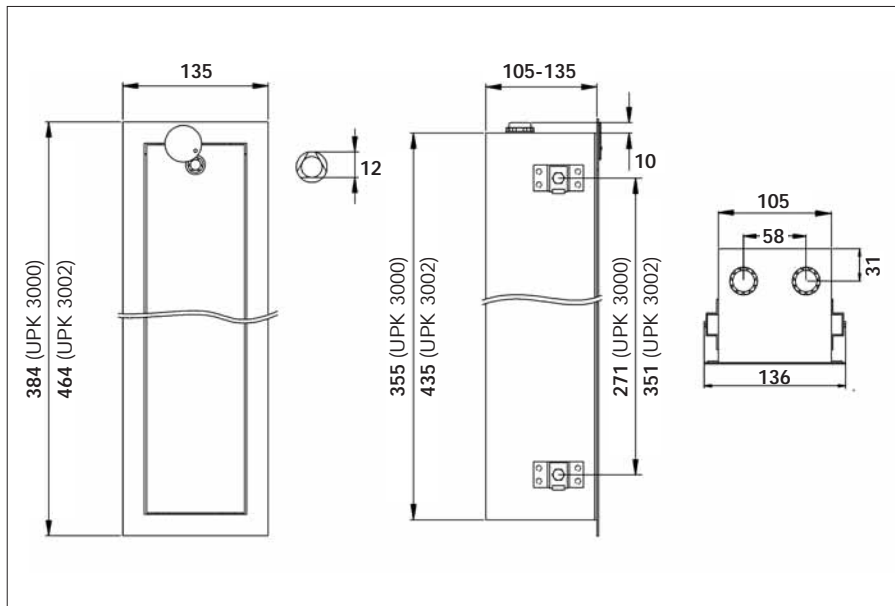

Dimensions in mm

Application

The In-wall enclosures are intended to be fit inside of walls. The cover frame is designed to overcome facade (finery) tolerances of 30 mm.

Selection Criteria

UPK 3000 is suitable for fuse boxes EKM 1261, EKM 1271, EKM 1272, EKM 2020, EKM 2050, EKM 2072.

UPK 3002 is suitable for EKM 2051, EKM 2035 and EKM 1281.

Technical Data

- Made of stainless steel with blank front cover
- Delivered with triangular screw 12 mm lock (Other closure means are available on demand)
- Underground cable entry: open
- Luminaire cable sealing: 2 membrane glands M25

Fuse Boxes

EKM 2020, EKM 2050, EKM 1271, EKM 1272, EKM 1261, EKM 2072

EKM 2051, EKM 2035, EKM 1281

Lock

Δ 12 mm

Δ 12 mm

Ordering description

UPK 3000

UPK 3002

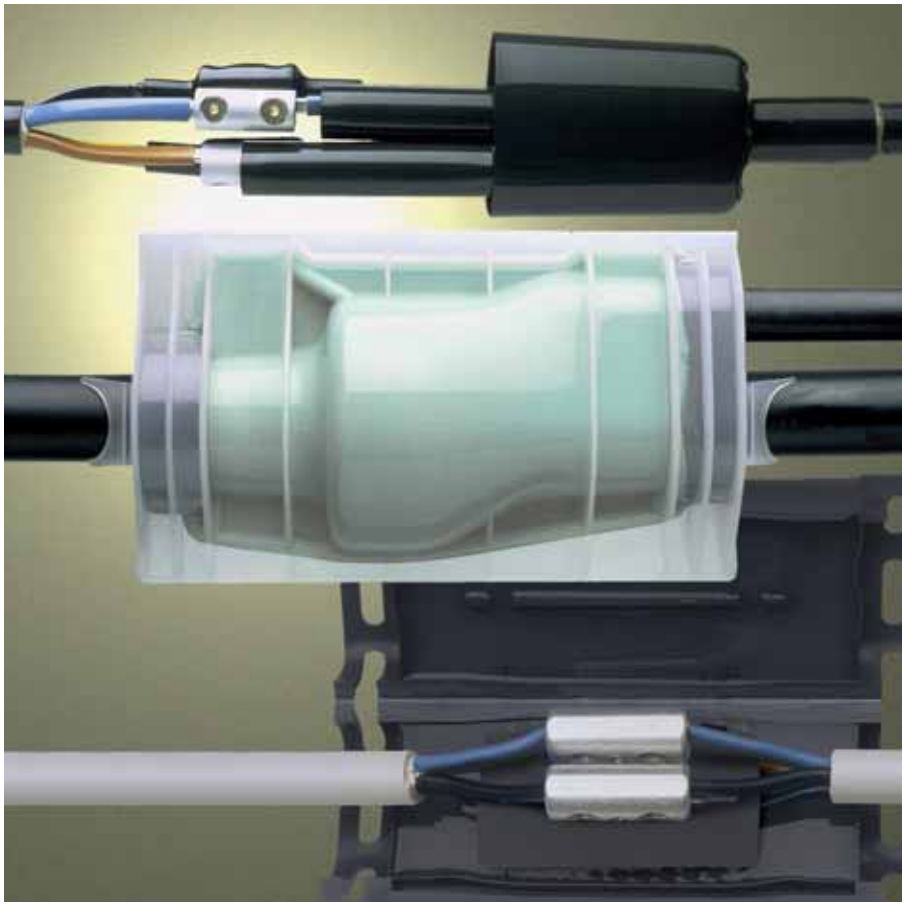

Cable Accessories

Heat-shrinkable Low Voltage Cable Accessories	
Terminations for polymeric insulated cables	38
Transition joints for polymeric insulated cables to paper insulated cables	39
Joints for polymeric insulated cables	40
Gel Low Voltage Joints	
Inline and branch joints for polymeric insulated cables – RayGel, GelBox	42
Resin Low Voltage Joints	
Joints up to 25 mm ² for polymeric insulated cables	44
Branch joints up to 25 mm ² for polymeric insulated cables	45
Branch joints 35 to 240 mm ² for polymeric insulated cables	46
Fused branch joints for polymeric insulated cables	48
Filler Material	
GUROFLEX – 2-component environmental friendly filler material	49
RAPID 3010 – 2-component polyurethane filler material	50
Mantle clamps	51
Insulation piercing multi-core connectors	52

Terminations for polymeric insulated cables

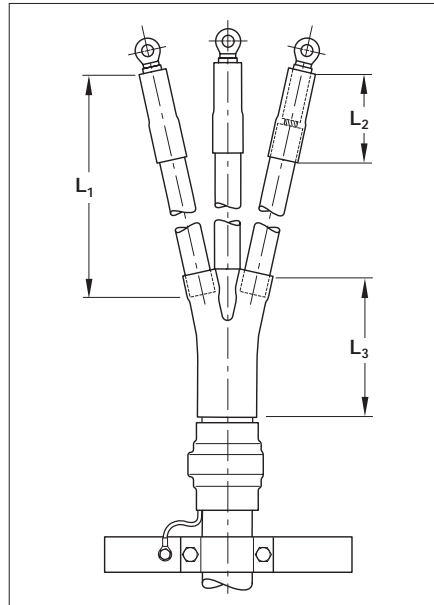
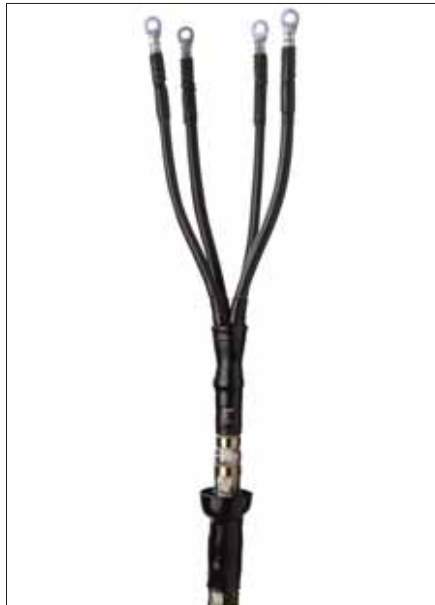

Dimensions L₁, L₂, L₃ see table

Cable

The terminations are designed for 3- and 4-core polymeric insulated cables with or without armour.

For example: NAYY, YAKY, XAKXS, KnFtA, AYKY, CYKY, NAYY, PP 00-A, XP 00-A, N(A)YY, PP 41-A, N(A)YC(W)Y, IPO 13.

Design of terminations

The cable crutch is sealed by an adhesive lined heat-shrinkable breakout, which is installed over the cores and the end of the oversheath. Heat-shrinkable tubing seal

between the cable lug and the end of the core insulation. For single core cables only a lug sealing tubing is needed. All materials are resistant to UV-light and weathering. A solderless earth connection system consisting of a roll spring and an earth braid is included in terminations for armoured cables. In case UV-light protection of the core insulation is required, the EN-CGPT insulating tubing can be ordered separately. All terminations can be ordered as complete kits or as components. Kits with the modification code -L12 include

mechanical lugs with a busbar connection hole for M12 connection bolts, with code -L16 for M16 bolts (note: M16 not available for kits with cross section 25 – 70 mm²).

For 3-core cables

The termination includes in addition a solderless neutral connection system for the aluminium sheath, consisting of stainless steel hose clamps, an earth braid and a mechanical lug.

Complete terminations for 3- and 4-core polymeric cables

Cross section (mm ²)	Terminations including mechanical lugs		Cross section (mm ²)	Terminations without lugs		Dimensions	
	Ordering description for cables			Ordering description for cables		L ₃ (mm)	L ₂ (mm)
	without armour	with tape armour		without armour	with tape armour		
			4 – 35	EPKT-0015	EPKT-0015-CEE01	95	50
25 – 70	EPKT-0031-L12*	EPKT-0031-L12-CEE01*	25 – 70	EPKT-0031	EPKT-0031-CEE01	165	100
50 – 150	EPKT-0047-L12	EPKT-0047-L12-CEE01	50 – 150	EPKT-0047	EPKT-0047-CEE01	215	100
120 – 240	EPKT-0063-L12	EPKT-0063-L12-CEE01	150 – 400	EPKT-0063	EPKT-0063-CEE01	220	150

* Kits with modification code L16 (mechanical lugs with fixing hole for M16 bolts) are not available.

Note: For 3-core cables the concentric neutral wires are sealed with sealing tape S1052-1-500 (length needed per termination approx. 50 mm) and insulated with MWTM tubing (see page 56). Sealing tape S1052 and MWTM tubing have to be ordered separately.

Breakout and tubing components for polymeric cable terminations

Cross section (mm ²)	Ordering description		Cross section (mm ²)	Ordering description	Dimensions (mm)	
	Breakout	Insulating tubing*			Lug sealing tubing	L ₃
1,5 – 10	502S012/S	EN-CGPT 9/ 3-0-SP	1,5 – 10	MWTM-10/ 3- 50/S	60	50
4 – 35	502K033/S	EN-CGPT 12/ 4-0-SP	4 – 35	MWTM-16/ 5- 50/S	95	50
25 – 95	502K046/S	EN-CGPT 18/ 6-0-SP	25 – 70	MWTM-25/ 8-100/S	165	100
50 – 150	502K016/S	EN-CGPT 24/ 8-0-SP	70 – 150	MWTM-35/12-100/S	215	100
120 – 400	502K026/S	EN-CGPT 39/13-0-SP	150 – 400	MWTM-50/16-150/S	220	150

* For outdoor terminations the cores can be protected against weathering and UV-light with the insulating tubing EN-CGPT.

Tubing lengths L₁ depend on the local installation requirements. For technical and ordering details of MWTM and EN-CGPT tubing see page 56. For single core cables only a lug sealing tubing is needed.

Terminations and components for other cable types are available on request.

Transition joints for polymeric insulated cables to paper insulated cables

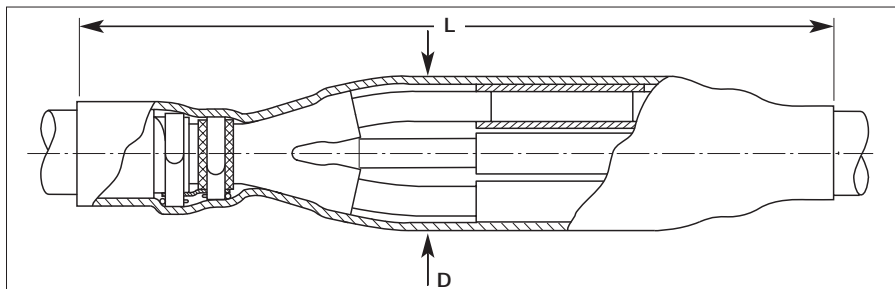

Dimensions L, D see table

Cable

The joints are designed for 4-core paper and polymeric insulated cables with or without armour.

For example: N(A)YY, SZAPKOV, IPO 13, NPO 13, ACHPAbi, AÑÁÓ-AÑÑÑ, YAKY, YKY, YKYftly, ANKOY, AYKY, PP 00, PP 41, N(A)YBY, IPO 14, NPO 14, N(A)KBA

Design of joints

The paper cable is transformed to a quasi polymeric insulated cable with heat-shrinkable oil resistive tubing and a breakout.

The connectors are insulated and sealed with adhesive coated heat-shrinkable tubing. The outer protection and sealing is performed by heat-shrinkable tubing.

Joints including connectors

The kit includes a solderless earth and neutral connection system for lead or aluminium sheaths.

Joints without connectors

In case of 3-core cables, a separate earth lead has to be soldered to the metal sheath (not provided within the kit).

Joints including mechanical connectors for 3 and 4-core paper to 4-core polymeric insulated cable

Nominal voltage U_0/U (kV)	Cross section (mm ²)	Ordering description for paper cables		Dimensions (mm)	
		3-core	4-core	L	D
0,6/1	10 – 35	–	TRAJ-01/4x 10- 35/4SB	500	50
	25 – 70	TRAJ-01/4x 25- 70/3SB	TRAJ-01/4x 25- 70/4SB	800	70
	70 – 120	TRAJ-01/4x 70-120/3SB	TRAJ-01/4x 70-120/4SB	900	80
	150 – 240	TRAJ-01/4x150-240/3SB	TRAJ-01/4x150-240/4SB	1100	110

Joints without connectors

4-core paper to 4-core unarmoured polymeric insulated cable including solderless earth connection for use with mechanical connectors

Nominal voltage U_0/U (kV)	Cross section (mm ²)		Ordering description	Dimensions (mm) Max. connector		Dimensions (mm)	
	polymeric	paper		Length	Diameter	L	D
0,6/1	25 – 95	25 – 95	SMOE-81404	90	25	850	70
	95 – 150	50 – 150	SMOE-81502	130	32	1050	80
	95 – 240	95 – 240	SMOE-81400	110	38	1150	90

Note: Dimensions of connectors must not exceed the dimensions given in the table.

Mechanical connectors are not included in the joints.

4-core paper to 4-core polymeric insulated cable for use with compression connectors

Nominal voltage U_0/U (kV)	Polymeric cables without armour		Polymeric cables with armour		Dimensions (mm)	
	Cross section (mm ²)	Ordering description	Cross section (mm ²)	Ordering description	L	D
0,6/1	10 – 16	EPKJ-0903	16 – 26	EPKJ-0828	700	45
	25 – 50	EPKJ-0910	35 – 50	EPKJ-0835	900	60
	70 – 150	EPKJ-0917	70 – 150	EPKJ-0842	1100	75
	185 – 300	EPKJ-0924	185 – 300	EPKJ-0856	1300	100

Note: Connectors are not included.

Joints for polymeric insulated cables

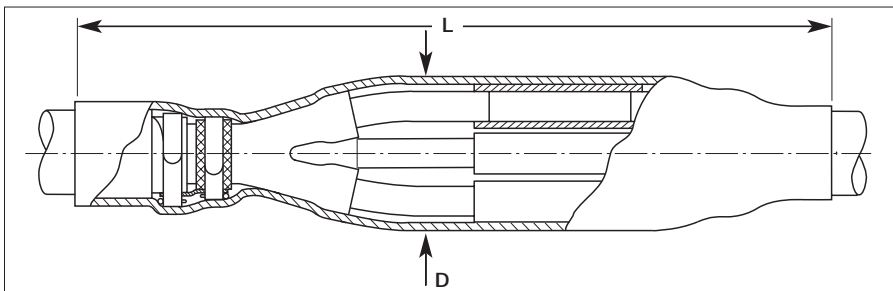

Dimensions L, D see table

Cable

The joints are designed for 3-, 3,5-, 4- and 5-core polymeric insulated cables with or without armour.

For example: SZAMtKAtM, KAtM, N(A)YY, N(A)YBY, VVG, AVVG, ÅÅÅ, ÅÅÅÅ, YAKY, YKY, YKYFty, AYKY, CYKY, PP 00, XP 00, PP 41, N(A)YC(W)Y

Design of joints

For cables without armour

The joint consists of four or five inner and the one outer heat-shrinkable tubing. The connectors are insulated and sealed by thick-wall tubing which is pre-coated with a hot-melt adhesive. The outer protection and sealing is performed by thick-wall heat-shrinkable tubing. All joints are designed to allow crossing of cable cores. For joints supplied without connectors, the crimp or mechanical connectors used must not exceed the maximum dimensions given in the tables.

For cables with steel tape armour

The joint consists of four or five inner and the one outer heat-shrinkable tubing as well as of tinned grid and roll springs. The connectors are insulated and sealed by thick-wall tubing which is pre-coated with a hot-melt adhesive. Wrapped around the jointing area, the tinned grid is mechanically secured and electrically connected to the steel tape by roll springs. The outer protection and sealing is performed by thick-wall heat-shrinkable tubing. All joints are designed to allow crossing of cable cores.

For joints supplied without connectors, the crimp or mechanical connectors used must not exceed the maximum dimensions given in the tables.

Joints for polymeric insulated cables

Joints for polymeric insulated cables including mechanical connectors

Nominal voltage U ₀ /U (kV)	Cross section (mm ²)	Ordering description for cables		Dimensions (mm)		
		without armour	with tape armour	L	D	
0,6/1	1,5- 6	POLJ-01/4X	1- 6	230	25	
	1,5- 6	POLJ-01/5X	1- 6*	230	25	
	4 - 16	POLJ-01/4X	4- 16	300	35	
	4 - 16	POLJ-01/5X	4- 16*	300	35	
	10 - 35	POLJ-01/4X	10- 35	POLJ-01/4X 10- 35-T	450	50
	10 - 35	POLJ-01/5X	10- 35*		450	50
	25 - 70	POLJ-01/4X	25- 70	POLJ-01/4X 25- 70-T	600	70
	70 - 120	POLJ-01/4X	70-120	POLJ-01/4X 70-120-T	650	80
	150 - 240	POLJ-01/4X	150-240	POLJ-01/4X150-240-T	800	110

* These joints can be used for 4- and 5-core cables.

Note: The joints are designed for the included connectors; other connectors must not be used.

Joints for cables with wire armour are available on request.

Joints without connectors for polymeric insulated cables without armour

Nominal voltage U ₀ /U (kV)	Cross section (mm ²)		Ordering description	Dimensions (mm)		Joint	
	Crimp Connectors	Mechanical Connectors		Max. connector Length	Diameter	L	D
for use with crimping and mechanical connectors							
0,6/1	1,5 - 10		SMOE-81511	35	8	230	25
	1,5 - 10		SMOE-81511-CEE05 *	35	8	230	25
	6 - 25		SMOE-81512	75	12	450	40
	6 - 25		SMOE-81512-CEE05 *	75	12	450	40
	16 - 50		SMOE-81513	95	18	600	50
	70 - 150	70 - 120	SMOE-81514	130	26	750	80
	95 - 300	150 - 240	SMOE-81515	150	37	850	110
for use with mechanical connectors							
0,6/1		10 - 35	SMOE-81516	45	18	400	50
		10 - 35	SMOE-81516-CEE05 *	45	18	400	50
		25 - 70	SMOE-81517	60	26	500	70
		70 - 120	SMOE-81518	75	29	550	80
		150 - 240	SMOE-81519	85	38	700	110

* The joints with modification code CEE05 can be used for 4- and 5-core cables

Joints without connectors for polymeric insulated cables with steel tape armour or aluminium tape shield

Nominal voltage U ₀ /U (kV)	Cross section (mm ²)		Ordering description	Dimensions (mm)		Joint	
	Crimp Connectors	Mechanical Connectors		Max. connector Length	Diameter	L	D
for use with crimping and mechanical connectors							
0,6/1	1,5 - 10		SMOE-81521	35	8	300	25
	6 - 25		SMOE-81522	75	12	500	40
	16 - 50		SMOE-81523	95	18	650	50
	70 - 150	70 - 120	SMOE-81524	130	26	850	80
	95 - 300	150 - 240	SMOE-81525	150	37	950	110
for use with mechanical connectors							
0,6/1		10 - 35	SMOE-81526	45	18	450	50
		25 - 70	SMOE-81527	60	26	600	70
		70 - 120	SMOE-81528	75	29	650	80
		150 - 240	SMOE-81529	85	38	800	110

Note: Dimensions of connectors must not exceed the dimensions given in the table. The cross section ranges shown in the table apply to all PVC insulated cables with crimp connectors according to DIN standards or mechanical connectors within the given limits.

Gel inline, branch joints and repair sleeves for polymeric insulated cables

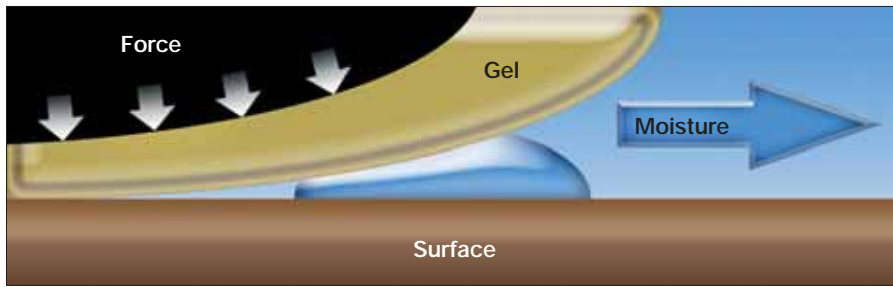

Gel sealing technology

- Proprietary Powergel technology for applications from -40°C to +90°C continuous temperature with an unlimited shelf life
- PowerGel is silicone embedded in a cross-linked silicone matrix
- Combines the advantages of solid (elastic memory) and liquid (wetting, conforms to surfaces) sealing materials
- Extremely high elongation and elasticity, excellent ageing and dielectric properties
- Displacement of possible moisture
- PowerGel wets the surface applying a thin layer of silicone oil



RayGel: Inline and branch joints



GelBox: Inline joint

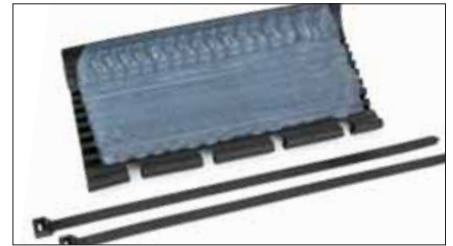

GelWrap: Inline joint and repair sleeve



Cable

The joints are designed for 1-, 2-, 3-, 3,5-, 4- and 5- core polymeric insulated cables without armour.

For example: SZAMtKAtM, KAtM, N(A)YY, N(A)YBY, VVG, AVVG, ÁÁÁ, ÁÁÁÁ, YAKY, YKY, YKYFty, AYKY, CYKY, PP 00, XP 00, PP 41, N(A)YC(W)Y

Design of joints

RayGel – inline and branch joints

The cable cores are jointed by connectors supplied within the kit or selected according to the max. dimensions given in tables. The cores are spread apart and a separator horizontally inserted. For 5-core cable applications an insulated connector block is supplied. The connection area is positioned in the middle of the opened gel-filled box. The joint is slightly pressed into the gel with the separator in the bottom of the box placed between the lower cores. The box is closed until the locks snap in place. Installing a cable tie as a lock prevents accidentally re-opening. For branch configurations, the branch cable and cores are positioned in parallel to the main cable and cores.

GelBox – inline joints

The piercing connector block supplied within the kit joints the cable cores. Based on the piercing technology no stripping of the primary insulation is required. The connector block will be positioned in the centre of one gel-filled half shell. The second half shells will snap in to the previous one. Accidentally re-opening is prevented by the snap in mechanism.

GelWrap - Design of joints

The GelWrap is wrapped around the connection area or the area of oversheath repair. The rails are snapped into place and are self-locking. Installing cable ties as a lock prevents accidentally re-opening.

Gel inline, branch joints and repair sleeves for polymeric insulated cables

RayGel inline joints with mechanical connectors

Nominal voltage U ₀ /U (kV)	Cable cores	Cross section (mm ²)	Ordering description	Dimensions (mm)		
				Length	Width	Height
0,6/1	3 – 5	1,5 – 6	RayGel-22-M-5	144 x	55 x	32
	4	1,5 – 6	RayGel-23-M	145 x	51 x	30
	4	6 – 16	RayGel-24-M	178 x	70 x	41
	3 – 5	6 – 10 (16re)	RayGel-24-M-5	178 x	70 x	41
	4	6 – 25 (35*)	GelBox-25	270 x	100 x	45
	5	6 – 16**	GelBox-25-5	270 x	100 x	45

* 35mm² with cable insulation removed (non-piercing application).

** includes a single mantle clamp for the earthing wire.

RayGel inline and branch joint with mechanical connector for cables with up to 5 cores

Nominal voltage U ₀ /U (kV)	Cross section (mm ²)		Ordering description	Dimensions (mm)		
	Main	Branch max.		Length	Width	Height
0,6/1	3 – 5 x 2,5* – 6*	3 – 5 x 1,5* – 2,5*	RayGel-24-M5	178 x	70 x	41

* only for round solid conductors (re)

RayGel inline and branch joints without connectors for cables with up to 4 cores

Nominal voltage U ₀ /U (kV)	Cross section (mm ²)		Ordering description	Max. dimensions (mm)			Joint L x W x H
	Main	Branch max.		Connectors			
				round Dia x Length	rectangular L x W x H		
0,6/1	10 – 50*	1 x 16	RayGel-12	Ø 10 x 25	21 x 24 x 15	86 x 46 x 28	
	1,5 – 6	4 x 1,5	RayGel-23	Ø 8 x 32	21,5 x 8 x 12,5	145 x 51 x 30	
	6 – 16	4 x 2,5	RayGel-24	Ø 14 x 40	20 x 12,5 x 20	178 x 70 x 41	

L x W x H = Length x Width x High

* only for 1-core cables

GelWrap inline joint for single-core cables and repair sleeve for cable cores and cable oversheaths

Nominal voltage U ₀ /U (kV)	Cable		Ordering description	Max. dimensions (mm)		Joint dimensions Length x Diameter (mm)
	Cross section (mm ²)	Diameter (mm)		connector or oversheath repair Length	Diameter	
0,6/1	2,5 – 95	4 – 18	GelWrap-18/4-150	75	25	150 x 35
	2,5 – 95	4 – 18	GelWrap-18/4-200	125	25	200 x 35
	35 – 240	10 – 33	GelWrap-33/10-250	150	40	250 x 50

Resin joints up to 25 mm² for polymeric insulated cables

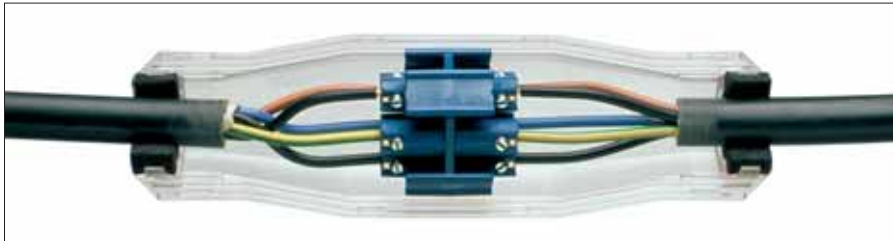

Cable

The joints are designed for 3-, 3,5-, 4- and 5-core polymeric insulated cables without armour up to 25 mm².

For example: SZAMtKAtM, KAtM, N(A)YY, N(A)YBY, VVG, AVVG, ÅÅÅ, ÅÅÅÅ, YAKY, YKY, YKYFty, AYKY, CYKY, PP 00, XP 00, PP 41, N(A)YC(W)Y

Design of joints

The joints consist of a shock-resistant, transparent polycarbonate snap-to-close design housing and integrated polymer foams for sealing. The robust housing is easy and quickly to assemble, cutting to the cable diameter is not needed. The Guroflex filler material is delivered in a double chamber bag. For details on Guroflex filler see page 49. The inline connector block with integrated spacing and insulation allows a quick and easy connection. A cable diameter range from 13 – 30 mm can be covered.

Inline joints with Guroflex filler without / with inline connector block

Nominal voltage U ₀ /U (kV)	Cable diameter (mm)	Cross section (mm ²)	Ordering description		Joint	
			Without connector	With connector	L (mm)	H (mm)
0,6/1	13 – 20	5 x 1,5 – 6	BV-0-GD	BV-0-GD-KS0	220	73
	16 – 25	5 x 6 – 16	BV-1-GD	BV-1-GD-KS1	230	80
	21 – 30	4 x 16 – 25	BV-2-GD	BV-2-GD-KS2	270	90

Note: Cross sections are selected according to dimensions given in CENELEC HD 603;
L = Overall length of the housing; H = Overall height of the housing.

Guroflex-filled joints for other cable types and cross sections are available on request.

Resin branch joints up to 25 mm² for polymeric insulated cables



BAV-2U



with connector block



with mantle clamps

Cable

The joints are designed for 3,5-, 4- and 5-core polymeric insulated cables without armour up to 25 mm².

For example: SZAMtKAtM, KAtM, N(A)YY, N(A)YBY, VVG, AVVG, AAA, AAAA, YAKY, YKY, YKYFty, AYKY, CYKY, PP 00, XP 00, PP 41, N(A)YC(W)Y

Design of joints

The joint consists of a shock-resistant, transparent polycarbonate snap-to-close design housing and integrated polymer foams for sealing. The robust housing is easy and quickly to assemble, cutting to the cable diameter is not needed.

The Guroflex filler material is delivered in a double chamber bag. For details on Guroflex filler see page 49.

The branch connectors allow a quick and easy connection. Different types of branch connectors are available like single mantle clamps or connector blocks with integrated spacing and insulation.

A cable diameter range from 10 – 30 mm can be covered.

Inline joints with Guroflex filler without / with inline connector block

Nominal voltage U ₀ /U (kV)	Cross section (mm ²)		Ordering description	Joint	
	Main	Branch		L (mm)	H (mm)
with connector blocks					
0,6/1	4 x 6 – 25	4 x 4 – 25	BAV-2U-GD-KK2/4	238	110
	5 x 6 – 16	5 x 6 – 16	BAV-2U-GD-KK2/5	238	110
	or 5 x 10 – 16	5 x 2,5 – 6			
with 5 single mantle clamps					
0,6/1	5 x 1,5 – 25	5 x 1,5 – 25	BAV-2U-GD- MC25U	238	110
	5 x 16 – 25	5 x 16 – 25	BAV-2U-GD- MC25	238	110

Note: Cross sections are selected according to dimensions given in CENELEC HD 603;

L = Overall length of the housing; H = Overall height of the housing.

Branch joint without connectors

Nominal voltage U ₀ /U (kV)	Cable diameter (mm) Main/Branch	Cross section (mm ²)		Ordering description	Joint	
		Main	Branch		L (mm)	H (mm)
0,6/1	10 – 30	5 x 1,5 – 25	5 x 1,5 – 25	BAV-2U-GD	238	110

Note: For mantle clamps see page 51.

L = Overall length of the housing; H = Overall height of the housing

Resin branch joints 35 mm² to 240 mm² for polymeric insulated cables

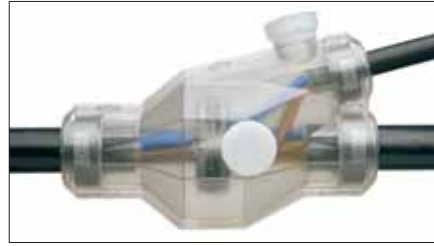
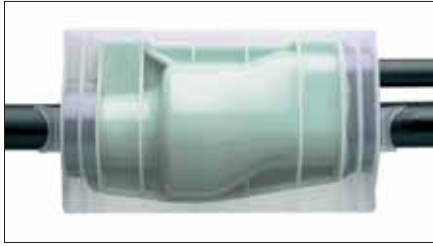

Compact ring connector

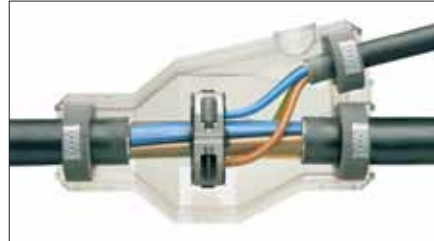

MM 5, MM 7

BAV 6, BAVC 7

Cable

The joints are designed for 3,5- and 4-core polymeric insulated cables without armour up to 240 mm².

For example: SZAMtKAtM, KAtM, N(A)YY, N(A)YBY, VVG, AVVG, ÅÅÅ, ÅÅÅÅ, YAKY, YKY, YKYFty, AYKY, CYKY, PP 00, XP 00, PP 41, N(A)YC(W)Y

Design of joints

The joints consist of impact-resistant, transparent polypropylene snap-to-close design (MM 5, MM 7) or impact-resistant, transparent polycarbonate snap-to-close design (BAV) housings and polymer foams for sealing. The housings are easy and quick to assemble, no adjustment to the cable diameter needed. Joints are available with compact ring connectors. The Guroflex filler material is delivered in double chamber bag (D) or in cans (C). The joints allow filling in different positions. A cable diameter range from 27 – 65 mm can be covered.

Conductors types:

sm: Sector stranded.
se: Sector solid.
rm: Round stranded
re: Round solid.

Resin branch joints 35 mm² to 240 mm² for polymeric insulated cables

Branch joints including compact ring connector

Nominal voltage U ₀ /U (kV)	Cross section (mm ²)			Ordering description	Joint	
	Main rm, sm/re, se	Neutral rm, sm/re, se	Branch rm, sm/re, se		L (mm)	H (mm)
Branch joints for 4-core cables						
0,6/1	35 – 70/ 50 – 95	–	6 – 50/ 6 – 70	MM-5-GD-4874	295	175
	70 – 120/ 95 – 150	–	6 – 50/ 6 – 70	MM-5-GD-6875	295	175
	150/185se	–	6 – 70/ 6 – 70	BAV-6-GD-6878	348	203
	185/	–	6 – 70/ 6 – 70	BAV-6-GD-6879	348	203
	240sm/	–	6 – 70/ 6 – 70	MM-7-GC-6880	480	230
	95 – 120/120 – 150	35 – 120/50 – 150	10 – 95/16 – 120	MM-7-GC-6877	480	230
	150 – 240/150 – 240	–	95 – 150/95 – 150	BAV-C7-GC-CEE01**	484	212
Branch joints for 3,5-core cables						
0,6/1	70 – 120/ 95 – 150	35 – 70/ 50 – 95	6 – 50 /6 – 70	MM-5-GD-4875.3	295	175
	150sm/	–	70sm / 70	BAV-6-GD-6878.3	348	203
	185sm/	–	– / 95re	MM-7-GC-6879.3	480	230
	240sm/	–	– /120re	MM-7-GC-6880.3-RE	480	230
	240sm/	–	120sm / –	MM-7-GC-6880.3-SM	480	230
	150 – 240/150 – 240	70 – 120/ 70 – 120	95 – 185/95 – 185	BAV-C7-GC-CEE02**	484	212

* needs to be rounded for 50 mm² sm

** Branch joints including single core mechanical connectors.

L = Overall length of the housing; H = Overall height of the housing

Branch joints without connectors

Nominal voltage U ₀ /U (kV)	Cable diameter (mm) Main/Branch	Connector diameter max (mm)	Cross section (mm ²)		Ordering description	Joint	
			Main	Branch		L (mm)	H (mm)
0,6/1	27 – 55/16 – 36	105	4 x 35 – 150	4 x 6 – 70	MM-5-GD	295	175
	30 – 58/16 – 40	115	4 x 50 – 185	4 x 6 – 95	BAV-6-GD	348	203
	37 – 60/16 – 57	140	4 x 120 – 240	4 x 6 – 150	MM-7-GC	480	230
	45 – 65/16 – 50	140	4 x 120 – 240	4 x 6 – 150	BAV-C7-GC	484	212

Note: Selecting criteria are cable diameters and connector sizes. Cross sections are selected for cables according to CENELEC HD 603 used with compact ring connectors. For ring connectors see page 52.

L = Overall length of the housing; H = Overall height of the housing

Resin joints for other cable types and cross sections are available on request.

Resin fused branch joints 35 mm² to 240 mm² for polymeric insulated cables



ASM 390

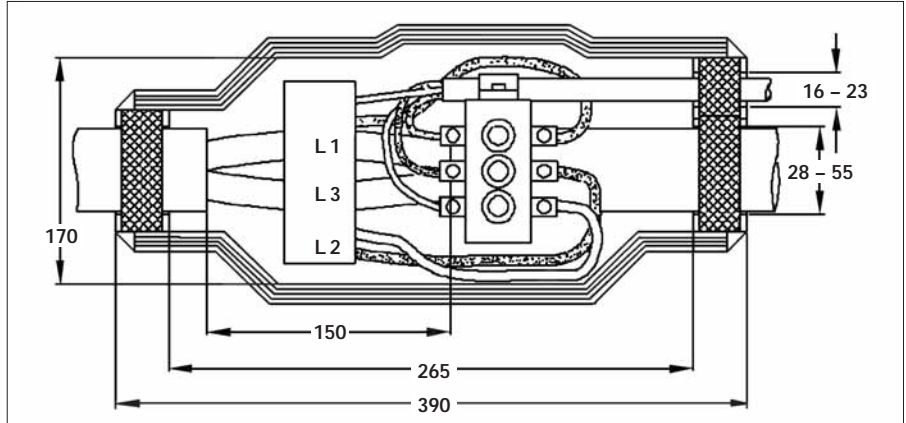

Height = 225 mm, Dimensions in mm

Application

This joint is used for the protection of the connection cables between an energy network and street lighting, signs, illuminated bus stops, etc.

Cable

The joints are designed for 3,5- and 4-core polymeric insulated cables without armour up to 150 mm² (up to 240 mm² of 3,5-core as long as the cable diameter does not exceed 55 mm).

For example: N(A)YY, AYKY, CYKY

Design of joints

The compact joints consist of impact-resistant, transparent polycarbonate snap-to-close design housings (horizontal partition) and polymer foam seals. The 4,4 liter housing is easy and quick to assemble, no adjustment to the cable diameter needed.

The fuse carrier is fixed to the cable sheath and provides convenient connection between fuse holder and ring connector. Joints are available with 1- or 3-fold fuse carrier D02 - E18 with 35 A fuse elements (1D2, 3D2), replaceable also after casting.

The joints are supplied with compact ring connectors. The Rapid 3010 PU-filler material is delivered in double chamber bag. The joints are to be filled in horizontally positions.

A main cable diameter range from 28 – 55 mm can be covered.

Conductors types:

- sm: Sector stranded.
- se: Sector solid.
- rm: Round stranded
- re: Round solid.

Branch joints including compact ring connector

Nominal voltage U ₀ /U (kV)	Cross section (mm ²)		Branch rm, sm/re, se	Ordering description* for 1-phase fused joint	Joint		
	Main rm, sm/re, se	Neutral rm, sm/re, se			L (mm)	H (mm)	
Branch joints for 4-core cables							
0,6/1	35 – 70/50 – 95	–	6 – 16/6 – 16	ASM-390-1D2-3D-4874	390	225	
	70 – 120/95 – 150	–	6 – 16/6 – 16	ASM-390-1D2-3D-6875	390	225	
Branch joints for 3,5-core cables							
0,6/1	70 – 120/95 – 150	35 – 70/50 – 95	6 – 16/6 – 16	ASM-390-1D2-3D-4875.3	390	225	
	150sm/	–	70sm/70	6 – 16/6 – 16	ASM-390-1D2-3D-6878.3	390	225
	185sm/	–	/95re	6 – 16/6 – 16	ASM-390-1D2-3D-6879.3	390	225
	185 – 240sm/	–	95 – 120sm/	6 – 16/6 – 16	ASM-390-1D2-3D-6880.3-ARG	390	225
	240sm/	–	– /120re	6 – 16/6 – 16	ASM-390-1D2-3D-6880.3-RE	390	225
	240sm/	–	120sm/	6 – 16/6 – 16	ASM-390-1D2-3D-6880.3-SM	390	225

*Use 3D2 modification code instead 1D2 in the Ordering description for 3-phase fused joint.

Note: Selecting criteria are cable diameters and connector sizes. Cross sections are selected for cables according to CENELEC HD 603 used with compact ring connectors (please see page 52).

Joints are delivered with fuse D02 of nominal current 35 A.

L = Overall length of the housing; H = Overall height of the housing.

Resin joints for other cable types and cross sections are available on request.

GUROFLEX – 2-component environmental friendly filler material



2-component Guroflex in double chamber bag



2-component Guroflex in cans



Joint filled with "green" Guroflex

Properties

Guroflex is an environmental friendly, easy to handle, 2-component, cold casting material based on hydrocarbon resins. Guroflex can be used for all self-supporting underground cable joint systems up to 1 kV. Guroflex is suitable for XLPE, PE, PVC and paper insulated cables. Guroflex has excellent insulating properties, is hydrophobic and gives excellent corrosion protection. Guroflex filler can be handled without any special safety precautions and allows installation at low temperatures.

Handling

The resin is available either in double chamber bags or in two comprising secure cans. The larger of the two component cans is used as the mixing vessel. Immediately before filling the entire joint area, both components will be mixed in order to start the cross-linking process. The joint trench can be backfilled immediately after filling.

Technical data

- Dielectric strength: $U_d > 10 \text{ kV/mm}$
- Spec. Dielectric Constant: $\epsilon_r \sim 4$
- Specific Vol. Resistance: $Q_D > 10^{13} \Omega\text{cm}$
- Relative Density: $\rho = 1,22 \text{ g/cm}^3$
- Min. Storage temperature: $-20 \text{ }^\circ\text{C}$
- Min. Installation temperature: $-10 \text{ }^\circ\text{C}$
- Hardness Shore A: ~ 20
- Shelf life: 2 years @ $23 \text{ }^\circ\text{C}$
- Color: Green

Ordering description for supply in		Volume	Weight	quantities suitable
Double chamber bags	Cans	(~ l)	(~ kg)	for joints
GUROFLEX-D035	-	0,35	0,43	BV-0, BV-1
GUROFLEX-D055	-	0,55	0,67	BV-2
GUROFLEX-D080	-	0,80	0,98	BAV-2
GUROFLEX-D140	-	1,40	1,71	MM-5
GUROFLEX-D160	GUROFLEX-C160	1,60	1,95	VMY-405, MM-5
GUROFLEX-D170	GUROFLEX-C170	1,70	2,07	MM-5
GUROFLEX-D200	GUROFLEX-C200	2,00	2,44	BAV-5
GUROFLEX-D240	GUROFLEX-C240	2,40	2,93	BAV-6
-	GUROFLEX-C370	3,70	4,51	-
-	GUROFLEX-C480	4,80	5,86	VMP-600, MM-7
-	GUROFLEX-C570	5,70	6,95	BAV-C7, MM-7
-	GUROFLEX-C650	6,50	7,93	HMY-661-B, VMY-950

Note: Volume and weight are absolute value of both components together. Other quantities on request.

RAPID 3010 – 2-component polyurethane filler material



2-component RAPID 3010 in double chamber bag



2-component RAPID 3010 in cans



Joint filled with RAPID 3010

Properties

RAPID 3010 is suited for use in all cable joint systems up to 1 kV. It is suitable for XLPE, PE, PVC and paper-insulated cables.

RAPID 3010 is two-component, polyurethane-type casting material type. It is a hydrophobic, soft-elastic polyurethane resin. It consists of component A – a mixture of different polyols, fillers and special additives – and component B – the hardener – which is MDI (diphenylmethane-4,4 diisocyanate). The isocyanate is classified as a hazardous material and is labeled “harmful”. Polyurethane systems generally generate less heat during reaction than epoxy resins.

Handling

RAPID 3010 is available in double chamber bags and in cans of different sizes.

Preparation of RAPID systems takes place immediately before casting. The two components are mixed either in a double chamber bag or in a can to start the cross-linking process.

Foaming problems during processing are avoided, even when casting in a relatively high humidity environment. This ensures long-term stability under service conditions. Furthermore the RAPID systems have an excellent curing profile at various temperatures, which allows easy handling and curing, summer and winter alike. Processing is possible at temperatures as low as 5° C.

The point trench can be backfield immediately after filling.

Technical data

- Dielectric strength: $U_d > 10 \text{ kV/mm}$
- Spec. Dielectric Constant: $\epsilon_r \sim 4$
- Specific Vol. Resistance: $Q_D > 10^{13} \Omega\text{cm}$
- Relative Density Component A: $\rho = 1,22 \text{ g/cm}^3$
- Relative Density Component B: $\rho = 1,24 \text{ g/cm}^3$
- Viscosity at 20 °C Component A: 3000 mPas
- Viscosity at 20 °C Component B: 300 mPas
- Pot life at 5 °C: ~ 26 min
- Pot life at 23 °C: ~ 13 min
- Pot life at 35 °C: ~ 9 min
- Max. reaction temperature: 80 °C
- Min. Storage temperature: -20 °C
- Min. Installation temperature: 5 °C
- Tensile Strength: 8 MPa
- Elongation to break: 45 %
- Hardness Shore D: ~ 44
- Shelf life: 2 years @ 23 °C
- Color: Blue

Ordering description for supply in		Volume	Weight	quantities suitable
Double chamber bags	Cans	(~ l)	(~ kg)	for joints
RAPID 3010 DK 0,35L	-	0,35	0,43	BV-0, BV-1
RAPID 3010 DK 0,55L	-	0,55	0,68	BV-2
RAPID 3010 DK 0,8 L	-	0,80	0,98	BAV-2
RAPID 3010 DK 1,4 L	-	1,40	1,72	MM-5
RAPID 3010 DK 1,6 L	RAPID 3010 CAN 1,6L	1,60	1,97	VMY-405, MM-5
RAPID 3010 DK 1,7 L	RAPID 3010 CAN 1,7L	1,70	2,09	MM-5
RAPID 3010 DK 2,0 L	RAPID 3010 CAN 2,0L	2,00	2,46	BAV-5
RAPID 3010 DK 2,4 L	RAPID 3010 CAN 2,4L	2,40	2,95	BAV-6
-	RAPID 3010 CAN 3,7L	3,70	4,55	-
-	RAPID 3010 CAN 5,7L	5,70	7,00	BAV-C7, MM-7

Note: Volume and weight are absolute value of both components together. Other quantities on request.

Mantle Clamps



Universal mantle clamp with individual branch connection and insulation cap



Mantle clamp with insulation cap



Mantle clamp without insulation cap

Universal mantle clamp with individual branch connection and insulation cap

Ordering description	Cross section (mm ²)	
	Main	Branch
GURO-MC25U-I	2,5 – 25	1,5 – 25

Mantle clamps with common connection with insulation cap

Ordering description	Combinations of cross sections (mm ²)	
	Main	Branch
GURO-MC06-I	4 – 6	1,5 – 6
	2,5 – 6	2,5 – 6
GURO-MC16-I	16	1,5 – 16
	10 – 16	2,5 – 10
	6 – 16	4 – 6
GURO-MC25-I	25	2,5 – 25
	16 – 25	6 – 16
	10 – 25	10

Mantle clamps with common connection without insulation cap

Ordering description	Combinations of cross sections (mm ²)	
	Main	Branch
GURO-MC25	25	2,5 – 25
	16 – 25	6 – 16
	10 – 25	10

Insulation piercing multi-core connectors



Properties

The cable ring type connector is specially designed for simple and reliable installation while ensuring maximum safety during life line work.

The connectors are suitable for aluminium or copper, for stranded or solid conductors and cables with PVC or XLPE insulation. The compact design allows installation in reduced size resin filled boxes and in Raychem heat-shrinkable Rayligator joints.

Installation

Cable oversheath is removed and the core separators placed between the cores. The two connector halves positioned over the cores and the bolts slightly tightened. Stripped ends of branch cores inserted in the branch channels and the bolts are tightened. The connector halves are closed by tightening the two outer bolts while the contact segments pierce the main cable cores. The outer metal ring is at all times insulated from the live conductors.

- For 4- and for 3,5 core cables
- Contact segments with integrated depth limitation
- Branch channels with grooves
- No torque moment key required
- Exceeds requirements according to VDE 0220

Materials:

- Body: High strength aluminium alloy
- Contact segment: electro tinned brass
- Insulation parts: Glass fibre reinforced polymer
- Bolts: Tinned steel 12.9

Conductors types:

- sm: Sector stranded.
- se: Sector solid.
- rm: Round stranded
- re: Round solid.

Insulation piercing multi-core connectors

Cable ring type connector for 4-core cables

Ordering description standard version	branch with shear head	Main conductor (mm ²)		Branch conductor (mm ²)		Dimension outer circle (mm)	Width across flats (mm)	Weight (kg/100pcs)
		rm/sm	re/se	rm/sm	re/se			
HEL-4874-35re	-	-	35re	6 - 50	6 - 70	96	6 / 5	42,4
HEL-6871	-	16 - 25rm	35	6 - 50	6 - 50	83	6 / 5	36,5
HEL-6872	-	35	50	6 - 50	6 - 50	83	6 / 5	36,7
HEL-6873	-	50	70se	6 - 50	6 - 50	83	6 / 5	36,7
HEL-4874	HEL-4874-AK	35 - 70	50 - 95	6 - 50	6 - 70	96	6 / 5	42,4
HEL-6874	HEL-6874-AK	50 - 70	70 - 95	6 - 50	6 - 70	96	6 / 5	42,6
HEL-6875	HEL-6875-AK	70 - 120	95 - 150	6 - 50	6 - 70	98,5	6 / 5	42,2
HEL-6876	HEL-6876-AK	95 - 120	120 - 150	6 - 50	6 - 70	96	6 / 5	44,6
HEL-6877	HEL-6877-AK	95 - 120	120 - 150	10 - 95/ 35 - 120	16 - 120/ 50 - 150	142	6 / 6	46,0
HEL-6878	-	150	185se	6 - 70	6 - 70	115	6 / 5	60,0
HEL-6879	-	185	240se	6 - 70	6 - 70	124	8 / 5	69,4
HEL-6880	-	240sm	-	6 - 70	6 - 70	124	8 / 5	69,4
HEL-6880.1	-	185 - 240sm	185 - 240se	6 - 70	6 - 70	124	8 / 5	70,0
HEL-5876	HEL-5876-AK	120rm	120 - 150	6 - 50	6 - 70	96	6 / 5	46,0
HEL-5877	HEL-5877-AK	-	120 - 150	10 - 95/ 35 - 120	16 - 120/ 50 - 150	142	6 / 6	46,0

Cable ring type connector for 3,5-core cables with reduced cross section of neutral conductor

Ordering description	Main conductor (mm ²)				Branch conductor (mm ²)		Dimension outer circle (mm)	Width across flats (mm)	Weight (kg/100pcs)
	phase rm/sm	re/se	neutral rm/sm	re/se	rm/sm	re/se			
HEL-4874.3	50sm	-	25sm	-	6 - 50	6 - 70	96	6 / 5	42,4
HEL-4875.3	70 - 120sm	95 - 150se	35 - 70sm	50 - 95se	6 - 50	6 - 70	98,5	6 / 5	42,2
HEL-6878.3	150sm	-	70sm	70	6 - 50*	6 - 50	115	6 / 5	63,8
HEL-6879.3	185sm	-	-	95re	6 - 50*	6 - 50	124	8 / 5	73,2
HEL-6880.3-ARG	185 - 240sm	-	95 - 120sm	-	6 - 50*	6 - 50	124	8 / 5	73,0
HEL-6880.3-RE	240sm	-	-	120re	6 - 50*	6 - 50	124	8 / 5	72,2
HEL-6880.3-SM	240sm	-	120sm	-	6 - 50*	6 - 50	124	8 / 5	72,2

* needs to be rounded for 50 mm² sm



Tubing, Breakouts and Repair Wraparounds

Tubing	
Heat-shrinkable tubing for plastic insulated conductors and cables	56
Heat-shrinkable protective sleeve for metal poles – LPSM	57
Breakouts for 2 to 5 core cables and ducts	58
Repair Wraparounds for plastic and paper insulated cables – CRSM	59

Heat-shrinkable tubing for plastic insulated conductors and cables

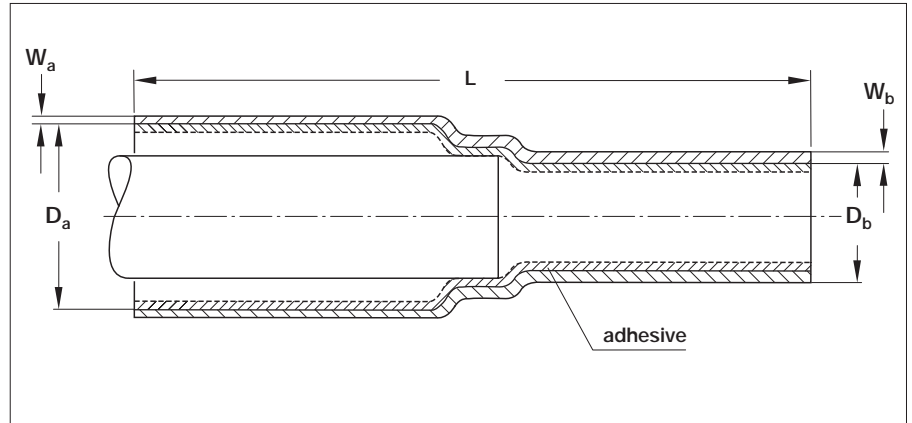

Protection and insulation tubing

In case of terminating cables with core insulation which is not resistant to UV-light it is recommended to install over the cores the EN-CGPT insulating tubing. The thin-wall EN-CGPT tubing is uncoated and resistant to UV-light and weathering. As marking and protection tubing for grounding wires, cables and busbars the dual colour (yellow-green) EN-DCPT tubing is recommended.

Sealing and insulation tubing

The sealing tubing MWTM is recommended to insulate and seal over connectors and lugs and onto the cable insulation. The tubing is resistant to UV-light and weathering and coated with hot-melt adhesive which seals to all common plastics and metals.

Dimensions:

D: Diameter
D_a: Diameter as delivered
D_b: Diameter after free recovery
L: Length
W: Wall-thickness
W_a: Wall-thickness as delivered
W_b: Wall-thickness after free recovery

Recommended Cross Section (mm ²)		Ordering description	Dimensions (mm)		W		
min.	max.		L (nom.)	D a (min.)	b (max.)	a (min.)	b (min.)
EN-CGPT (thin wall, black, insulation and protection tubing)							
1,5	10	EN-CGPT 9/ 3-0-SP	on spool	9	3		0,75
4	35	EN-CGPT 12/ 4-0-SP	on spool	12	4		0,75
16	95	EN-CGPT 18/ 6-0-SP	on spool	18	6		0,85
35	150	EN-CGPT 24/ 8-0-SP	on spool	24	8		1,00
120	400	EN-CGPT 39/13-0-SP	on spool	39	13		1,15
EN-DCPT (thin wall, green-yellow, marking and protection tubing for grounding wires, cables and busbars)							
1,5	10	EN-DCPT 6/ 3-45-SP	on spool	6	3		0,58
4	16	EN-DCPT 8/ 4-45-SP	on spool	8	4		0,64
10	25	EN-DCPT 10/ 5-45-SP	on spool	10	5		0,64
16	35	EN-DCPT 12/ 6-45-SP	on spool	12	6		0,64
50	120	EN-DCPT 19/ 9-45-SP	on spool	19	9		0,76
120	185	EN-DCPT 26/13-45-SP	on spool	26	13		0,89
185	400	EN-DCPT 38/19-45-SP	on spool	38	19		1,00
MWTM (medium wall insulation and sealing tubing)							
1,5	10	MWTM-10/ 3-1000/S	1000	10	3	0,3	1,0
4	35	MWTM-16/ 5-1000/S	1000	16	5	0,3	1,4
25	70	MWTM-25/ 8-1000/S	1000	25	8	0,4	2,0
70	150	MWTM-35/12-1000/S	1000	35	12	0,4	2,0
150	400	MWTM-50/16-1000/S	1000	50	16	0,5	2,0

EN-CGPT and EN-DCPT is delivered on spools and can be cut to the needed length at site. MWTM tubing is also available as short pieces and in lengths of 1500 mm which can be cut to length at site.

Other heat-shrinkable tubing, either with or without adhesive coating, is available on request.

Heat-shrinkable protective sleeve for metal poles – LPSM

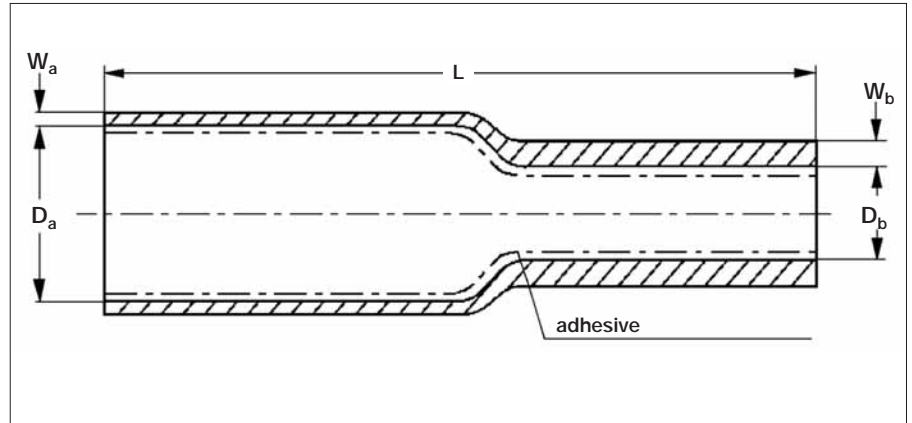

Application

The LPSM sleeve is used on lamp poles in the section just above and below ground level to mechanically protect the previously applied corrosion protection.

The Sleeve is resistant to UV-light and coated with hot-melt adhesive.

Installation

Sleeve is installed in the factory or on site before erecting the poles, shrinking in diameter fits a wide range of diameters and easily accommodate tolerances in pole manufacture.

Dimensions:

D: Diameter
D_a: Diameter as delivered
D_b: Diameter after free recovery
L: Length
W: Wall-thickness
W_a: Wall-thickness as delivered
W_b: Wall-thickness after free recovery

Recommended Cross Section (mm ²)		Ordering description	Dimensions (mm)		W		L
min.	max.		D		a (nom.)	b (nom.)	a (± 15 mm)
			a (min.)	b (max.)			
100	115	LPSM-124/ 94 - 450/87	124	94	0,9	1,3	450
115	132	LPSM-145/108 - 450/87	145	108	0,9	1,3	450
132	150	LPSM-165/124 - 450/87	165	124	1,0	1,3	450
145	175	LPSM-196/135 - 450/87	196	135	1,0	1,4	450
165	220	LPSM-250/150 - 450/87	250	150	1,0	1,8	450

Sealing Breakouts for 2 to 5 core cables and ducts

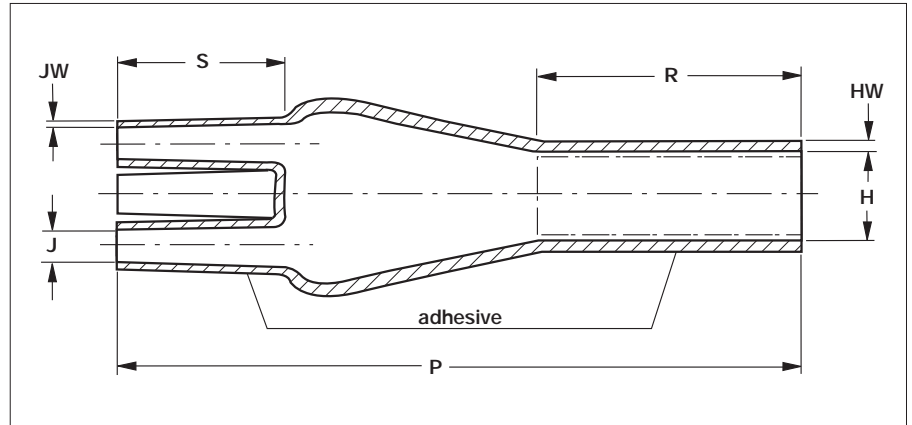

Application

For sealing crutches of multi-core cables and cable entries into ducts. To seal onto all common plastics and metals, all outlets are coated with hot-melt adhesive.

Breakouts are available for 2-, 3-, 4- and 5-core cables, in a variety of sizes. Dimensional details see table below.

Dimensions:

H: Diameter of large outlet
J: Diameter of small outlets
P: Length of breakout
R: Length of large outlet
S: Length of small outlets
HW: Wall thickness of large outlet
JW: Wall thickness of small outlets

a: as delivered
b: after free recovery

Recommended cross section of plastic cables (mm ²)	Ordering description	Dimensions (mm)									
		H		J		P	R	S	HW	JW	
		a (min.)	b (max.)	a (min.)	b (max.)						
for 2-core cables											
4 – 25	302K333/S	28	9,2	15	4,1	90	20	25	3,2	1,6	
35 – 150	302K224/S	48	32	22	7	172	–	70	2,0	2,0	
150 – 400	302K466/S	86	42	40	16	200	–	75	2,5	2,5	
for 3-core cables											
4 – 35	402W533/S	38	13	16	4,2	103	45	28	2,7	1,5	
50 – 150	402W516/S	63	22	26	9	180	85	40	3,5	1,5	
95 – 500	402W526/S	95	28	44	13	205	90	45	3,5	2,5	
–	402W248/S	115	45	52	22	240	100	60	4,0	2,5	
–	402W439/S	170	60	60	30	252	90	66	4,2	2,6	
for 4-core cables											
1,5 – 10	502S012/S	23	9	8	1,5	68	–	21	2,1	1,5	
4 – 35	502K033/S	36	16,5	14	3,4	90	71	25	2,5	1,9	
25 – 95	502K046/S	45	19	20	7	165	75	40	3,5	2,0	
50 – 150	502K016/S	60	25	25	9	217	100	44	3,5	2,0	
120 – 400	502K026/S	100	31	40	13,5	223	103	51	3,5	2,5	
–	502R810/S	170	60	43	23	255	90	65	4,0	3,5	
for 5-core cables											
25 – 120*	603W035/S	68	26	20	7	182	75	40	2,5	2,2	

* for smaller cross sections use 502K033 with 2 cores inside an outlet.

Repair wraparound for plastic and paper insulated cables CRSM

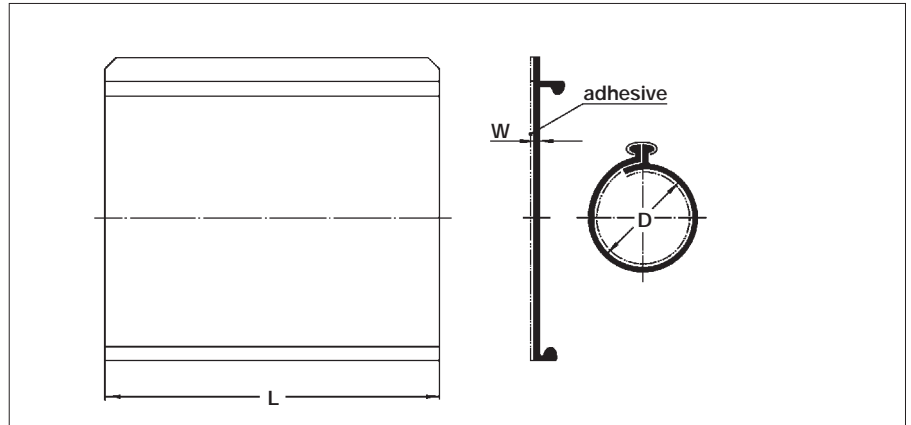

Application

The general purpose CRSM wraparound is to be used for a fast and reliable repair of polymeric or paper cable sheaths to re-establish the electrical and mechanical integrity of the cable. The wraparound is supplied with an adhesive coating.

Dimensions:

D: Diameter
D_a: Diameter as delivered
D_b: Diameter after free recovery
L: Length
W: Wall-thickness
W_a: Wall-thickness as delivered
W_b: Wall-thickness after free recovery

Recommended application diameter (mm)		Ordering description	Dimensions (mm)				
min.	max.		D		W		L
			a (min.)	b (max.)	a (min.)	b (min.)	a (± 15 mm)
11	21	CRSM- 34/10- 250/239	35	9	0,3	2,4	250
		CRSM- 34/10- 500/239					500
		CRSM- 34/10-1000/239					1000
		CRSM- 34/10-1500/239					1500
17	32	CRSM- 53/13- 250/239	54	15	0,3	2,0	250
		CRSM- 53/13- 500/239					500
		CRSM- 53/13- 750/239					750
		CRSM- 53/13-1000/239					1000
		CRSM- 53/13-1500/239					1500
24	50	CRSM- 84/20- 250/239	86	21	0,3	2,0	250
		CRSM- 84/20- 500/239					500
		CRSM- 84/20- 750/239					750
		CRSM- 84/20-1000/239					1000
		CRSM- 84/20-1500/239					1500
31	65	CRSM-107/29- 500/239	108	27	0,3	2,0	500
		CRSM-107/29-1000/239					1000
		CRSM-107/29-1500/239					1500
33	86	CRSM-143/36- 500/239	144	28	0,3	1,8	500
		CRSM-143/36-1000/239					1000
		CRSM-143/36-1500/239					1500
56	120	CRSM-198/55-1000/239	203	50	0,3	2,1	1000
		CRSM-198/55-1500/239					1500
103	150	CRSM-250/98-1000/239	257	91	0,4	1,7	1000
		CRSM-250/98-1500/239					1500

Note: The repair wraparound and the channel can be cut to the length as required at the place of installation. Other lengths are available on request.

Overhead Line Accessories

Tap-off connectors	
Insulation piercing connectors	62
Waterproof insulation piercing connectors	63
Insulation piercing connectors for connections to bare overhead	64
Anchor and suspension clamps for service cables	65

Insulation piercing connectors – test voltage 4 kV in air



Type: 1 bolt

Application

These insulation piercing connectors are suitable for all types of LV-ABC conductors as well as connections to service and lighting cable cores.

When tightening the bolts, the teeth of the contact plates penetrate the insulation and establish a perfect contact. Stripping of insulation is avoided.



Type: 2 bolts

Features

- Suitable for aluminium and copper conductors, including bare conductors
- Potential free tightening bolts allow safe installations on life lines
- Exceeds requirements according to VDE 0220
- Tested for voltage withstand of 4 kV in air
- Connector teeth factory greased to retard water entry and corrosion
- Insulation material made of weather and UV resistant glass fibre reinforced polymer
- Contact blades made of tinned copper, bolts and pressure plates made of hot-dip galvanized steel



Application Range (mm ²)		Ordering description	Bolt	Torque (Nm)	Weight (kg/100 pcs)
Main	Tap				
25 – 95	1,5 – 6	HEL-5022	1 x M8	15	6,0
25 – 70	6 – 35	HEL-5005	1 x M8	15	10,9
25 – 95	10 – 50 or 2 x 16	HEL-5002	2 x M8	15	26,4
25 – 95	6 – 70 or 2 x 16	HEL-5020	1 x M10	22	19,9
50 – 150	10 – 95	HEL-5008	2x M8	22	26,4

Note: Delivered with both sides of main line open, one side of tap line closed; exception HEL-5020 one main and both tap sides closed. Closed main or tap sides can be opened according to on-site requirements.

For double taps, the conductors have to be inserted from either side butting up in the middle.

Waterproof insulation piercing connectors – test voltage 6 kV in water



Type: EP, P2X, P3X, P4X

Application

These waterproof insulation piercing connectors are suitable for all types of LV-ABC conductors as well as connections to service and lighting cable cores. When tightening the bolts, the teeth of the contact plates penetrate the insulation and establish a perfect contact. The bolts are tightened until the heads shear off. Stripping of insulation is avoided.



Type: KZ 2-150 2B

Features

- Tested for watertightness at a voltage of 6 kV for 30 min in a waterbath
- Potential free tightening bolts allow safe installations on life lines
- Suitable for aluminium and copper conductors
- Long neck 13 mm shear head nut ensuring reliable installations
- Exceeds requirements according to NFC 33020 and EATS 43-14



Type: KZ31

- Components not losable, end cap attached to body
- Insulation material made of weather and UV resistant glass fibre reinforced polymer
- Contact plates made of aluminium or copper, bolt made of dachromatized steel

Simultaneous piercing of main and branch conductor

Application Range (mm ²)		Ordering description	Bolt	Torque (Nm)	Weight (kg/100 pcs)
Main	Tap				
for main to service connections					
2,5 – 35	1,5 – 6	EP35-13	1 x M6	7	5,0
16 – 95	1,5 – 10	EP95-13	1 x M6	7	5,0
16 – 95	4 – 35 (50*)	P2X 95	1 x M8	11	12,0
50 – 150	6 – 35 (50*)	P2X 150	1 x M8	11	12,0
for main to main connections					
16 – 35	16 – 35	P2X 95	1 x M8	11	12,0
25 – 95	25 – 95	P3X 95	1 x M8	18	16,0
25 – 120	25 – 120	P4X 120D	2 x M8	18	34,0
50 – 150	50 – 150	P4X 150D	2 x M8	18	34,0

* fits up to this conductor size, but current rating I_{max} of connector (138A according to HD626S1part6E) is lower than possible cable ratings.

Independent connection of main (piercing) and branch conductor (strippable)

Application Range (mm ²)		Ordering description	Bolt	Torque (Nm)	Weight (kg/100 pcs)
Main	Tap				
for main to 2 service connections (Bp-piercing tap side, B-strippable tap side)					
25 – 150	2 x 6 – 35	KZ 2-150 2B	3 x M8	11/10	23,0
25 – 150	2 x 6 – 35	KZ 2-150 2Bp	3 x M8	11/10	23,0
for main to main connections (strippable tap side)					
35 – 70	35 – 70 (95*)	KZ31 70-70	1 x M8/1 x M10	18/10	24,0
50 – 150	35 – 70 (95*)	KZ31 150-70	1 x M8/1 x M10	18/10	24,0

* fits up to this conductor size, but current rating I_{max} of connector (213A according to HD626S1part6E) is lower than possible cable ratings.

Note: Possibility to disconnect and reconnect the tap line (only stripping version) without removal of the main side.

Insulation piercing connectors for connections to bare overhead



Type: RDP 25/CN

Application

These connectors allow the transition between bare lines (aluminium or copper) and insulated LV ABC lines.

The version with simultaneous connection of bare main and insulated tap conductor includes piercing and a waterproof seal of the tap conductor.

The second version with independent connection requires the tap conductor to be stripped. The bolts (13 mm) are tightened until the heads shear off.



Type: CDR/CN

Features

- Suitable for aluminium and copper conductors
- Groove in contact area for bare conductor fits also for small wires.
- Potential free tightening bolts allow safe installations on life lines
- Exceeds requirements according to NFC 33020
- Components not losable, end cap attached to body
- Insulation material made of weather and UV resistant glass fibre reinforced polymer
- Contact plates made of tinned copper, bolt made of dachromatized steel

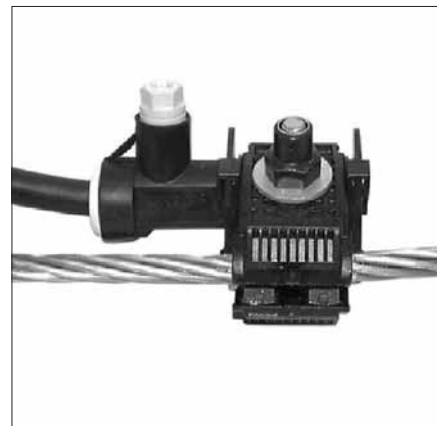

Type: KZ31-70

Simultaneous connection of main (bare) and branch (insulated) conductor; piercing of branch conductor

Application Range (mm ²)		Ordering description	Bolt	Torque (Nm)	Weight (kg/100 pcs)
Bare	Insulated				
for bare main to insulated service connections					
16 – 95 ¹	1,5 – 10	EP95-13	1 x M6	7	5,0
16 – 95 ¹	4 – 35	P2X 95*	1 x M8	11	12,0
7 – 100 ²	16 – 35	RDP 25/CN	1 x M8	12	13,5
for bare main to insulated main connections					
7 – 100 ²	25 – 95	CDR/CN 1S 95 UK	2 x M8	16	26,5

¹ equivalent to a diameter range of 4,5 to 12 mm

² equivalent to a diameter range of 3 to 13,5 mm

* Connector of type P2X can only be used for connections between aluminium conductors

Independent connection of main (bare) and branch conductor (strippable)

Application Range (mm ²)		Ordering description	Bolt	Torque (Nm)	Weight (kg/100 pcs)
Bare	Insulated				
22 – 75 Al*	35 – 70	KZ31-70 CNA	1 x M8/1 x M10	11/10	24,0
7 – 48 Cu	35 – 70	KZ31-70 CNU	1 x M8/1 x M10	11/10	24,0

* equivalent to a diameter range of 6 to 11 mm.

Note: Possibility to disconnect and reconnect the tap line without removal of the main side.

CNA only for bare main aluminium conductors.

CNU only for bare main copper.

Anchor and suspension clamps for service cables



Type: PA, PAS

Application

The clamps are designed to anchor insulated service lines with 2 or 4 conductors.

Features

- Tool free installation with wedges sliding inside the body
- Easy to open bail permits fixing to brackets and pigtails
- Length of bail adjustable, max total length 220 mm
- Exceeds requirements according to NF C 33 042
- Clamp is made of weather and UV resistant polymer



Type: RA 25

Application

The clamps are designed for suspension applications of insulated service line with 2 or 4 conductors.

Features

- For angles of the line up to 90°
- Tool free installation with core separator
- Easy to open bail permits fixing to brackets and pigtails
- Exceeds requirements according to NF C 33 042
- Clamp is made of weather and UV resistant polymer

Anchor clamps for insulated overhead conductors (self-supporting)

Cross Section (mm ²)		Ordering description	Breaking Load	Weight (kg/10 ks)
min.	max.			
2 x 16	4 x 25	PA 25x100	3,0 kN	1,3

Anchor clamps with rigid bail for round cables

Cross Section (mm ²)		Ordering description	Breaking Load	Weight (kg/10 ks)
min.	max.			
9	17	PA 9-17/GALVA	3,0 kN	1,4
18	25	PAS 35	3,0 kN	1,3

Suspension clamp for insulated overhead conductors and cables

Cross Section (mm ²)		Ordering description	Breaking Load	Weight (kg/10 ks)
min.	max.			
2 x 16	4 x 25	RA 25	3,0 kN	0,9

APPENDIX

Reference table

Reference Table

Ordering description	Product Number	Ordering description	Product Number
302K466/S(S10)	127794-000	CRSM- 53/13-1000/239(S5)	279727-000
402W248/S(S5)	452278-000	CRSM- 53/13-1500/239(B20)	737881-000
402W439/S(S5)	831828-000	CRSM- 84/20- 250/239(S10)	996715-000
402W516/S(S5)	337914-000	CRSM- 84/20- 500/239(B15)	189019-000
402W526/S(S5)	000938-000	CRSM- 84/20- 750/239(B15)	924203-000
402W533/S(S10)	096434-000	CRSM- 84/20-1000/239(S5)	953639-000
502K016/S(S5)	C52918-000	CRSM- 84/20-1500/239(B15)	204799-000
502K026/S(S5)	C22917-000	CRSM-107/29- 250/239(S10)	113107-000
502K033/S(S15)	E00553-000	CRSM-107/29- 500/239(B10)	889383-000
502K046/S(S5)	086694-000	CRSM-107/29- 750/239(B10)	607813-000
502R810/S(S5)	E40575-000	CRSM-107/29-1000/239(S5)	395359-000
502S012/S(S5)	E03687-000	CRSM-107/29-1500/239(B10)	142631-000
603W035/S(S5)	F40674-000	CRSM-143/36- 250/239(S5)	574837-000
ASM-390-1D2-3D-4874	CJ6290-000	CRSM-143/36- 500/239(S5)	974023-000
ASM-390-1D2-3D-4875.3	CA1335-000	CRSM-143/36- 750/239(S5)	289379-000
ASM-390-1D2-3D-6875	CJ6291-000	CRSM-143/36-1000/239(B5)	297113-000
ASM-390-1D2-3D-6878.3	CJ6292-000	CRSM-143/36-1500/239(B5)	850279-000
ASM-390-1D2-3D-6879.3	CA1333-000	CRSM-198/55- 250/239(S5)	067269-000
ASM-390-1D2-3D-6880.3-ARG	CJ6293-000	CRSM-198/55- 500/239(S5)	225261-000
ASM-390-1D2-3D-6880.3-RE	CJ6294-000	CRSM-198/55- 750/239(B5)	712269-000
ASM-390-1D2-3D-6880.3-SM	CA1334-000	CRSM-198/55-1000/239(B5)	800517-000
ASM-390-3D2-3D-4874	CJ6295-000	CRSM-198/55-1500/239(B5)	892261-000
ASM-390-3D2-3D-4875.3	CJ6296-000	CRSM-250/98- 250/239(S5)	193119-000
ASM-390-3D2-3D-6875	CJ6297-000	CRSM-250/98- 500/239(S1)	575247-000
ASM-390-3D2-3D-6878.3	CJ6298-000	CRSM-250/98- 750/239(S1)	423283-000
ASM-390-3D2-3D-6879.3	CJ6300-000	CRSM-250/98-1000/239(B5)	771953-000
ASM-390-3D2-3D-6880.3-ARG	CJ6301-000	CRSM-250/98-1500/239(B5)	397671-000
ASM-390-3D2-3D-6880.3-RE	CJ6303-000	EKM-1261-0D0-5-16-1R	F81971-000
ASM-390-3D2-3D-6880.3-SM	CJ6305-000	EKM-1261-1D2-4-16	F81424-000
BAV-2U-GD	C01692-000	EKM-1261-1D2-5-16	F01912-000
BAV-2U-GD-KK2/4	F01444-000	EKM-1261-2D2-4-16	D30908-000
BAV-2U-GD-KK2/5	E93697-000	EKM-1261-2D2-5-10	A71366-000
BAV-2U-GD-MC25	E26018-000	EKM-1261-2D2-5-16	C83851-000
BAV-2U-GD-MC25U	E24692-000	EKM-1271-1D2-4-16	A47843-000
BAV-6-GD	E05754-000	EKM-1271-1D2-5-16	C37772-000
BAV-6-GD-6878	D16798-000	EKM-1272-2D2-4-16	A22873-000
BAV-6-GD-6878.3	E24761-000	EKM-1272-2D2-4-25	C42505-000
BAV-6-GD-6879	F44494-000	EKM-1281-0D0-4-35-1R	C80505-000
BAV-C7-GC	C54218-000	EKM-1281-1D2-5-25	E29570-000
BAV-C7-GC-CEE01	D40730-000	EKM-1281-2D2-4-25	D32281-000
BAV-C7-GC-CEE02	F70384-000	EKM-1281-2D2-4-35	C16837-000
BV-0-GD	F61400-000	EKM-1281-2D2-5-16	165370-000
BV-0-GD-KS0	E97284-000	EKM-1281-2D2-5-25	748134-000
BV-1-GD	F84035-000	EKM-2020-2D1	C43836-000
BV-1-GD-KS1	D07457-000	EKM-2020-2D1(S20)	512986-000
BV-2-GD	D86747-000	EKM-2035-0D0	E84793-000
BV-2-GD-KS2	D90416-000	EKM-2035-0D0-1R	E67365-000
CDR/CN1S95UK	690314-000	EKM-2035-1D2	059062-000
CRSM- 34/10- 250/239(B30)	168551-000	EKM-2035-2D2	A27844-000
CRSM- 34/10- 500/239(B30)	552273-000	EKM-2042SK-2D1	D35657-000
CRSM- 34/10- 750/239(B30)	273601-000	EKM-2042SKF-2D1	A96972-000
CRSM- 34/10-1000/239(S5)	406345-000	EKM-2045-1D1	F06699-000
CRSM- 34/10-1500/239(B30)	647565-000	EKM-2045-1FN-G-EE	CG7018-000
CRSM- 53/13- 250/239(B20)	747669-000	EKM-2045-1FN-I-EE	CG7020-000
CRSM- 53/13- 500/239(B20)	390635-000	EKM-2045-1FN-M-EE	CG7022-000
CRSM- 53/13- 750/239(B20)	319783-000	EKM-2045-1FN-N-EE	CG7024-000

Ordering description	Product Number	Ordering description	Product Number
EKM-2045-1FNT-G-EE	CG7019-000	EPKT-0047-L12	024923-000
EKM-2045-1FNT-I-EE	CG7021-000	EPKT-0047-L12-CEE01	834836-000
EKM-2045-1FNT-M-EE	CG7023-000	EPKT-0063(S10)	063097-000
EKM-2045-1FNT-N-EE	CG7025-000	EPKT-0063-CEE01	858651-000
EKM-2050SK-2D1U	C11649-000	EPKT-0063-L12	620097-000
EKM-2050SK-3D1U	A95277-000	EPKT-0063-L12-CEE01	739502-000
EKM-2050SKF-0D0-1R	E17326-000	GelBox-25	556670-000
EKM-2050SKFH-0D0-1R	D37167-000	GelBox-25-5	E72165-000
EKM-2050SKFH-2D1U	F87023-000	GelWrap-18/ 4-150(B6)	F90657-000
EKM-2050SKFH-3D1U	F45931-000	GelWrap-18/ 4-200(B6)	F60655-000
EKM-2051SK-0D0-2R	D14988-000	GelWrap-33/10-250(B6)	A36570-000
EKM-2051SK-2D1S-1R	F64011-000	GURO-B6602	C60783-000
EKM-2051SK-2D1U	C83364-000	GURO-B6622	E57299-000
EKM-2051SKF-0D0-2R	D21741-000	GURO-B6692	F26337-000
EKM-2051SKFH-2D1U	D47445-000	GURO-B6705	E49413-000
EKM-2051SKFH-3D1U-1R	C38579-000	GURO-B6770- 2A	E14671-000
EKM-2051SKFH-4D1U	F61759-000	GURO-B6770- 4A	E94791-000
EKM-2072-1D2-4-35	F41915-000	GURO-B6770- 6A	A75461-000
EKM-2072-1D2-5-16	F05998-000	GURO-B6770-10A	F45989-000
EKM-2072-1D2-5-35	F41485-000	GURO-B6924(S10)	C43854-000
EKM-2072-2D2-4-35	A56993-000	GURO-B7142	A36547-000
EKM-2072-2D2-5-16	C36879-000	GURO-B7182-01	A46905-000
EKM-2072-2D2-5-35	D20950-000	GURO-B7182-03	A95755-000
EN-CGPT- 3/ 1-0-SP	E20918-000	GURO-B7217-11	CE3864-000
EN-CGPT- 6/ 2-0-SP	E86580-000	GURO-B7224	A09894-000
EN-CGPT- 9/ 3-0-SP	C99919-000	GURO-B7324	A19056-000
EN-CGPT-12/ 4-0-SP	F93007-000	GURO-CC3x1.5-5-CPC-GT	CA6917-000
EN-CGPT-18/ 6-0-SP	C47829-000	GURO-F-CC-02(S10)	CG7026-000
EN-CGPT-24/ 8-0-SP	F52163-000	GURO-F-CC-04(S10)	CG7027-000
EN-CGPT-39/13-0-SP	E21457-000	GURO-F-CC-06(S10)	CG7028-000
EN-DCPT- 3/ 1,5-45-SP	D21910-000	GURO-F-CC-10(S10)	CG7029-000
EN-DCPT- 6/ 3-45-SP	E44441-000	GURO-F-CC-16(S10)	CG7030-000
EN-DCPT- 8/ 4-45-SP	A18953-000	GURO-F-D1-02(S10)	D24969-000
EN-DCPT-10/ 5-45-SP	A05941-000	GURO-F-D1-04(S10)	C15515-000
EN-DCPT-12/ 6-45-SP	A87683-000	GURO-F-D1-06(S10)	A73919-000
EN-DCPT-19/ 9-45-SP	F74998-000	GURO-F-D1-10(S10)	A05271-000
EN-DCPT-26/13-45-SP	E01829-000	GURO-F-D1-16(S10)	838144-000
EN-DCPT-38/19-45-SP	C62205-000	GURO-F-D1-AS02	A49162-000
EP35-13	E84478-000	GURO-F-D1-AS04	689204-000
EP95-13	D12469-000	GURO-F-D1-AS06	623604-000
EPKJ-0828(S1)	380423-000	GURO-F-D1-AS10	F18742-000
EPKJ-0835(S1)	317827-000	GURO-F-D1-SC(S20)	F31979-000
EPKJ-0842(S1)	483689-000	GURO-F-D2-02	E66007-000
EPKJ-0856(S1)	430091-000	GURO-F-D2-04	D04194-000
EPKJ-0903(S5)	204703-000	GURO-F-D2-06(S5)	E34651-000
EPKJ-0910(S5)	634139-000	GURO-F-D2-10(S5)	C45060-000
EPKJ-0917(S5)	255527-000	GURO-F-D2-16	A81326-000
EPKJ-0924(S1)	742251-000	GURO-F-D2-20	C36493-000
EPKT-0015(S20)	288775-000	GURO-F-D2-25	D20427-000
EPKT-0015-CEE01	301439-000	GURO-F-D2-AS06(S25)	F64495-000
EPKT-0031(S10)	005023-000	GURO-F-D2-AS10	D54125-000
EPKT-0031-CEE01	691173-000	GURO-F-D2-AS16	C16806-000
EPKT-0031-L12	563877-000	GURO-F-D2-AS20	D04856-000
EPKT-0031-L12-CEE01	C42979-000	GURO-F-D2-AS25	D06762-000
EPKT-0047(S10)	597107-000	GURO-F-D2-SC(S20)	C42916-000
EPKT-0047-CEE01	902411-000	GUROFLEX-C160	D64180-000

Reference Table

Ordering description	Product Number	Ordering description	Product Number
GUROFLEX-C170	A33943-000	HEL-6880	C35509-000
GUROFLEX-C200	A91392-000	HEL-6880.1	CF5355-000
GUROFLEX-C240	D64905-000	HEL-6880.3-ARG	D01671-000
GUROFLEX-C370	E62164-000	HEL-6880.3-RE	A26616-000
GUROFLEX-C480	F11990-000	HEL-6880.3-SM	D19190-000
GUROFLEX-C570	E16253-000	KZ 2-150 2B	296510-000
GUROFLEX-C650	C02594-000	KZ 2-150 2BP	SIML-0-1229989-2
GUROFLEX-D035	D40931-000	KZ31 70-70	741660-000
GUROFLEX-D055	C31606-000	KZ31 150-70	950674-000
GUROFLEX-D080	F24561-000	KZ31-70 CNA	898190-000
GUROFLEX-D140	D51571-000	KZ31-70 CNU	773312-000
GUROFLEX-D160	C76885-000	LPSM-124/94-450/87(S5)	968227-000
GUROFLEX-D170	C35000-000	LPSM-145/108-450/87(S5)	324129-000
GUROFLEX-D200	A81734-000	LPSM-165/124-450/87(S5)	420589-000
GUROFLEX-D240	F74083-000	LPSM-196/135-450/87(S5)	034327-000
GURO-H1261	CG5339-000	LPSM-250/150-450/87(S5)	332409-000
GURO-H1281	CG5340-000	MM-5-GD	479046-000
GURO-H2020	CG5338-000	MM-5-GD-4874	A00275-000
GURO-H2035	CG5336-000	MM-5-GD-4875.3	067904-000
GURO-H2050	CG5334-000	MM-5-GD-6875	F36615-000
GURO-H2051	CG5335-000	MM-7-GC	A24886-000
GURO-H2072	CG5337-000	MM-7-GC-6877	CB0422-000
GURO-MC06-I (S20)	CJ1516-000	MM-7-GC-6879.3	CJ6309-000
GURO-MC16-I (S20)	CJ1517-000	MM-7-GC-6880	CA1727-000
GURO-MC25 (S20)	D14129-000	MM-7-GC-6880.3-RE	CJ6311-000
GURO-MC25-I (S20)	CJ1518-000	MM-7-GC-6880.3-SM	CJ1550-000
GURO-MC25U-I (S20)	CJ1519-000	MWTM- 10/ 3- 50/S(S100)	234648-000
HEL-4874	170480-000	MWTM- 10/ 3-1000/S(S25)	069816-000
HEL-4874.3	D56489-000	MWTM- 16/ 5- 50/S(S100)	334828-000
HEL4874-35re	F64041-000	MWTM- 16/ 5-1000/S(S25)	262852-000
HEL-4874-AK	660940-000	MWTM- 25/ 8- 100/S(S100)	005502-000
HEL-4875.3	C17769-000	MWTM- 25/ 8-1000/S(S10)	381522-000
HEL-5002	700348-000	MWTM- 35/12- 100/S(S100)	598904-000
HEL-5005	221156-000	MWTM- 35/12-1000/S(S10)	413206-000
HEL-5008	955148-000	MWTM- 50/16- 150/S(S50)	664140-000
HEL-5020	346458-000	MWTM- 50/16-1000/S(S10)	544794-000
HEL-5022	156560-000	P2X 95	F77006-000
HEL-5876	901476-000	P2X 150	C41222-000
HEL-5876-AK	756400-000	P3X 95	C44216-000
HEL-5877	609532-000	P4X 120D	C63836-000
HEL-5877-AK	570886-000	P4X 150D	F24596-000
HEL-6871	CA0292-000	PA 25x100	637212-000
HEL-6872	CA0295-000	PA 9-17/GALVA	984632-000
HEL-6873	CA0296-000	PAS 35	833418-000
HEL-6874	351152-000	POLJ-01/4x 1- 6 (SMOE-82006)	D69547-000
HEL-6874-AK	441528-000	POLJ-01/4x 4- 16 (SMOE-82008)	E39276-000
HEL-6875	688850-000	POLJ-01/4x 10- 35 (SMOE-81936)	C09539-000
HEL-6875-AK	970494-000	POLJ-01/4x 10- 35-T (SMOE-81941)	F87284-000
HEL-6876	300758-000	POLJ-01/4x 25- 70 (SMOE-81938)	C95685-000
HEL-6876-AK	076046-000	POLJ-01/4x 25- 70-T (SMOE-81942)	A70655-000
HEL-6877	664194-000	POLJ-01/4x 70-120 (SMOE-81939)	E92611-000
HEL-6877-AK	296604-000	POLJ-01/4x 70-120-T (SMOE-81943)	A19815-000
HEL-6878	C32903-000	POLJ-01/4x150-240 (SMOE-81940)	E17588-000
HEL-6878.3	739786-000	POLJ-01/4x150-240-T (SMOE-81944)	A76784-000
HEL-6879	F63297-000	POLJ-01/4x150-240-W	A92166-000
HEL-6879.3	D03044-000	POLJ-01/5x 1- 6 (SMOE-82007)	577424-000

Ordering description	Product Number
POLJ-01/5x 4- 16 (SMOE-82009)	D92225-000
POLJ-01/5x 10- 35 (SMOE-81937)	E98079-000
RA 25	063830-000
RAPID 3010 CAN 1,6L	636504-000
RAPID 3010 CAN 1,7L	725996-000
RAPID 3010 CAN 2,0L	739272-000
RAPID 3010 CAN 2,4L	200736-000
RAPID 3010 CAN 3,7L	699460-000
RAPID 3010 CAN 5,7L	490164-000
RAPID 3010 DK 0,35L	819046-000
RAPID 3010 DK 0,55L	090570-000
RAPID 3010 DK 0,8L	371956-000
RAPID 3010 DK 1,4L	516362-000
RAPID 3010 DK 1,6L	351490-000
RAPID 3010 DK 1,7L	782222-000
RAPID 3010 DK 2,0L	564204-000
RAPID 3010 DK 2,4L	977464-000
RayGel-12(S4)	C65582-000
RayGel-22-M-5(S2)	C99932-000
RayGel-23(S2)	564264-000
RayGel-23-M(S2)	F63202-000
RayGel-24(S2)	E50507-000
RayGel-24-M(S2)	F50636-000
RayGel-24-M5(S2)	F62308-000
RayGel-24-M-5(S2)	D28559-000
RDP 25/CN	046148-000
S1052-1- 500	890932-000
SMOE-81400	292323-000
SMOE-81404	188169-000
SMOE-81502	437765-000
SMOE-81511(S10)	893315-000
SMOE-81511-CEE05(S10)	690476-000
SMOE-81512(S10)	282173-000
SMOE-81512-CEE05(S10)	250292-000
SMOE-81513(S10)	033219-000
SMOE-81514(S5)	733913-000
SMOE-81515(S5)	955221-000
SMOE-81516(S10)	792381-000
SMOE-81516-CEE05(S10)	235112-000
SMOE-81517(S10)	578691-000
SMOE-81518(S5)	150329-000
SMOE-81519(S5)	139795-000
SMOE-81521(S10)	575791-000
SMOE-81522(S10)	090311-000
SMOE-81523(S10)	115803-000
SMOE-81524(S5)	414979-000
SMOE-81525(S5)	170381-000
SMOE-81526(S10)	424243-000
SMOE-81527(S10)	907175-000
SMOE-81528(S5)	990283-000
SMOE-81529(S5)	662927-000

Ordering description	Product Number
TRAJ-01/4x 10- 35/3SB (SMOE-81945)	A97118-000
TRAJ-01/4x 10- 35/4SB (SMOE-81949)	E08621-000
TRAJ-01/4x 25- 70/3SB (SMOE-81946)	E52313-000
TRAJ-01/4x 25- 70/4SB (SMOE-81950)	C08500-000
TRAJ-01/4x 70-120/3SB (SMOE-81947)	C41944-000
TRAJ-01/4x 70-120/4SB (SMOE-81951)	F02789-000
TRAJ-01/4x150-240/3SB (SMOE-81948)	F68318-000
TRAJ-01/4x150-240/4SB (SMOE-81952)	A76235-000
UFK D125	upon request
UFK D125-CZ-A	A30883-000
UFK D125-CZ-B	F18614-000
UFK D125-CZ-C	F99212-000
UFK D125-CZ-D	CB9268-000
UFK D125-CZ-D2	CF2680-000
UFK D125-R	upon request
UFK D200-12V	CF3746-000
UFK D200-16	upon request
UFK D200-16-R	CB8700-000
UFK D200-16-R-FI-1	CF6654-000
UFK D200-32	upon request
UFK D200-32-R	A93841-000
UFK D40	CE2351-000
UPK 3000	579326-000
UPK 3002	CF2800-000

All of the above information, including drawings, illustrations and graphic designs, reflects our present understanding and is to the best of our knowledge and belief correct and reliable. Users, however, should independently evaluate the suitability of each product for the desired application. Under no circumstances does this constitute an assurance of any particular quality or performance. Such an assurance is only provided in the context of our product specifications or explicit contractual arrangements. Our liability for these products is set forth in our standard terms and conditions of sale. LumaWise, Raychem, TE Logo and Tyco Electronics are trademarks.

The Energy Division, a global operating unit of Tyco Electronics develops manufactures and markets products and systems for the electrical power industry. Today, the Energy Division employs approximately 4.000 people and annual sales amount to almost \$800 million. Our products are extensively employed by power utilities and equipment manufacturers, in rail transport systems and in industry around the world.

Tyco Electronics Raychem GmbH
Energy Division
Finsinger Feld 1
85521 Ottobrunn/Munich, Germany

Phone: +49-89-6089-0
Fax: +49-89-6096345

<http://energy.tycoelectronics.com>

 **Tyco Electronics**
Our commitment. Your advantage.